

# HOTLINE® HL-90 Blood and Fluid Warmer



smiths

1

Introduction /  
Specifications

2

Sub-Assemblies

3

Technical Description

4

Disassembly Procedures

5

Maintenance, Testing  
and Calibration

6

Troubleshooting

7

Spare Parts

8

Rounding Off

9

Appendix 1 -  
Circuits

10

Appendix 2 -  
PCB Layout

11

Appendix 3 -  
Symbols Glossary

12

Appendix 4 -  
Frequently Asked Questions  
Information Bulletins



**HOTLINE<sup>®</sup>**

Blood and  
Fluid Warmer

# Welcome...

## ... to one of Smiths Medical's Technical Service Packs

### Who are we?

Smiths Medical is a global manufacturer and supplier of medical devices for treating critically ill patients. These devices may be used in high-risk situations, and include ambulatory and hospital infusion pumps, neo-natal and paediatric monitors, blood and fluid warmers, and convective warming systems for patients.



*Figure P - 1: A selection of Smiths Products - old and new*

---

Smiths Medical has a long history, bringing many well known brands to the market, such as Portex<sup>®</sup>, Level 1<sup>®</sup>, BCI<sup>®</sup>, Graseby<sup>®</sup>, Wallace<sup>®</sup>, Bivona<sup>®</sup>, Pneupac<sup>®</sup>, Deltec<sup>®</sup>, DHD<sup>®</sup> and Medex<sup>®</sup>. It is part of the Smiths Group, a British engineering consortium founded in 1851.

Now all of these formerly independent business units have been merged into one Global company — Smiths Medical. Smiths Medical is a world leader in the design, manufacture and distribution of medical devices.

## What about Level 1<sup>®</sup>?

The Level 1<sup>®</sup> range of products is synonymous with a high quality, cost effective range of temperature management products. The range includes blood and fluid warming products for both gravity flow and fast flow intravenous or irrigation applications, and convective (hot air) warming systems. These products help to prevent hypothermia and maintain normothermia in patients undergoing surgery in the operating theatre, recovery ward and in the casualty departments in emergency situations.

## Why is Temperature Management important?

Patients undergoing surgical procedures are exposed to a variety of influences that have a effect on their ability to maintain their normal body temperature (Normothermia). If these factors persist for a prolonged period of time, the patient will become hypothermic, i.e., their body temperature drops below 36°C. Even mild hypothermia (34°-36°C) puts patients at risk. Trauma cases and extensive procedures present well-known temperature management challenges. But so can routine operations. Clinical evidence shows that warming is important in any case lasting more than an hour and/or using more than one litre of fluid.

---

## What hypothermia does to the patient

- Cardiovascular instability
  - *Vasoconstriction, decreased cardiac output, and changes in electrical conduction can contribute to an increased incidence of cardiac ischemia, arrhythmias, and arrest.*
- Increased coagulopathy
  - *Coagulopathy may result in increased bleeding, possibly necessitating blood transfusions.*
- Altered action and reduced clearance of anesthetics
  - *Hypothermia decreases a patient's metabolism, resulting in a need for higher amounts of anesthetics. It also contributes to delayed emergence from anesthesia and longer recovery room stays.*
- Increased risk of wound infection
  - *Wound infection and delayed wound healing result in longer hospital stays. Wound infection can prolong hospitalization.*
- Postoperative discomfort
  - *Thermal discomfort, shivering, and fatigue can occur when core temperature decreases by 1°C.*

## The HOTLINE<sup>®</sup> Blood and Fluid Warmer

The HOTLINE<sup>®</sup> Blood and Fluid Warmer uses a special disposable that totally encloses the patient's end of the IV administration set in a bath of warmed recirculating fluid. This means that the IV fluid is introduced at or above core body temperature, rather than in the chilled state that it may have been stored at.

This simple solution eliminates the chill being passed to the patient, and assists the patient's own efforts at maintaining normothermia.

## Published by:

Smiths Medical ASD, Inc.  
160 Weymouth St, Rockland, MA 02370, USA

- *For assistance or further information, contact Smiths Medical ASD, Inc., Technical Service Department or your Smiths Medical ASD, Inc., distributor at:*

## USA/ Canada

- *Smiths Medical ASD, Inc.  
160 Weymouth Street, Rockland, MA 02370 USA*
- *USA/Canada 1-800-258-5361  
International +1-781-878-8011*

## European Representative

- *Ga Jh gA YXJWU AbhyfbUhcU An  
" & ! 6f d\ RARc\ E= ` h VcAV^ SVcæ` \_  
2dYWDJL<V\_dE? #&%37LF <  
FY[ JghYFYXAbAb[ `UbXAbi a VYf.Ä \* & ( +  
HYÄ ((ÄSLÄ& ' Ä&&%\$\$*

## Australian Representative

- *Smiths Medical Australasia Pty. Ltd.  
61 Brandl Street, Brisbane Technology Park  
Eight Mile Plains, QLD 4113, Australia*
- *Tel +61 (0) 7 3340 1300  
Fax +61 (0) 7 3340 1399*

## World WideWeb:

- *www.smiths-medical.com*

- 
- *All possible care has been taken in the preparation and production of this publication, but Smiths Medical accepts no liability for any inaccuracies that may be found.*
  - *This publication may be subject to revision and it is the user's responsibility to ensure that the correct version is used appropriate to the intended use.*
  - *Users of the equipment must ensure that they have read and understood the contents of the complete manual including the warnings and cautions and have been trained in the correct use of the product.*
  - *This publication has been compiled and approved by Smiths Medical for use with their respective products.*
  - *It may be supplied in a format that permits users to access the text and illustrations for their own use (e.g., training and educational purposes). Smiths Medical cannot be held responsible for the accuracy of, nor any resulting incident arising from, information that has been extracted from this publication and compiled into the user's documentation.*
  - *Other than as herein noted, no part of this publication may be reproduced, transmitted, transcribed, or stored in a retrieval system or translated into any human or computer language in any form or by any means without the prior permission of Smiths Medical.*
  - *"Graseby<sup>®</sup>" "Smiths" "HOTLINE<sup>®</sup>" and "LEVEL 1<sup>®</sup>" are all trademarks of the Smiths Medical family of companies. All other trademarks are acknowledged as the property of their respective owners.*
  - *The symbol <sup>®</sup> indicates it is registered in the U.S. Patents and Trademarks Office and in certain other countries.*

**© 2011 Smiths Medical family of companies.  
All rights reserved.**

---

# Revision History

Issue No:	Reason for Change	Pages Affected	Date
000	New Revision - First Release	All	July 2006
001	Updated EU Rep address	iv, v, vi, 6, front and back covers	October 2011



---

# Aims

To provide technical engineering support staff with the practical and theoretical knowledge necessary to ...

- ... diagnose,
- maintain,
- repair,
- and update ...

... Smiths Medical products as appropriate to meet the needs of your healthcare establishment's equipment management protocols.

---

## Objectives

This manual will give you the necessary information to enable a qualified Biomedical Engineer or Technician with appropriate experience to successfully tackle any repair or component replacement required, and recalibrate the unit either routinely or post-repair work.

The material covered by this manual is also offered as part of a training course that can be held either at Smiths Medical's premises, or at your own establishment if that would be more convenient. Successful training course attendees may be certified by Smiths Medical, an option not open to non-attendees. Please contact your local Smiths Medical distributor for more details. We strongly recommend course attendance wherever possible, to ensure the highest standards of maintenance for your HOTLINE® units.

On completion of the program, delegates will have knowledge of the following:

- General functionality and device application.
- Principles of operation of electronic and mechanical systems.
- Access to, and use of, the menu systems as appropriate.
- Appropriate methods of testing and the equipment required.
- Essential safety features and verification of performance.
- Routine maintenance requirements.
- Analysis of faults, fault codes and download software as appropriate.

---

# Contents

## Section 1 - Introduction and Specifications

Superior Performance	2
Ease of Use	2
Features	3
Specifications	4
Environmental	5
Miscellaneous	5
Contra-Indications	6

## Section 2 - Sub-assemblies

Enclosure	9-11
Recirculating Solution Path	12
Interlock Block	13
PCB Mounting	14

## Section 3 - Technical Description

General	16
Mechanical	16
Controls and Indicators	17
Side Panel	17
Electrical	19
Power Circuits	19
Control Circuit	20
Digital Display	22
Thermistor Loss	23
Over Temperature Alarm	25
Flasher	27
Interlock Alarm	29
Recirculating Solution Level Alarm	30

## Section 4 - Disassembly Procedure

Tools you will need	33
Disassembly	34
Step 1: Open the case	34
Step 2: Remove the PCB	36
Step 3: Release the Earth Stud	40
Step 4: The Recirculating Solution Return Pipe	41
Step 5: Removing the Chassis	42
Reassembly	44

## Section 5 - Maintenance, Testing and Calibration

Before each use	46
Lubrication of O-Ring Seals	46
After each use	46
Routine Maintenance Tasks	47
Every 30 days	48
Every 12 months	49
Maintenance Solutions	54
Changing the Recirculating Solution	54
Sterile Distilled Water	54
Isopropyl Alcohol Solution	56
Hydrogen Peroxide Solution	57
Routine Maintenance Checklists	60
Full Service Test Procedure	64
Things you will need	64
HL-90 Service Test Specification	65

## Section 6 - Troubleshooting

Troubleshooting Hints	71
Over Temperature Alarm always ON	71
Over Temperature Alarm not working	72
Fluid Warming Set Interlock Alarm always ON	72
Fluid Warming Set Interlock Alarm not working	72
Low Recirculating Solution Level Alarm always ON	73
Low Recirculating Solution Level Alarm not working	73
Non-Alarm related Faults	74

## Section 7 - Spare Parts

Enclosure Parts for two-part case	76
Enclosure Parts for single-part case	77
Float Switch and related parts	77
Parts in the Recirculating Solution Path	78
P.C.B and mounting accessories	79
Water pump and related parts	79
Interlock Block and related parts	80
External Parts, Rear of case	81
Poleclamp parts	82

## Section 8 - Rounding Off

Updates	84
Modifications	84
GRI Pump	86
Float Switch Sealing Washer	87

## Appendix 1- Circuits

## Appendix 2 - PCB Layout

PCB layout	A2 - 2
Component Listing	A2 - 3

## Appendix 3 - Symbols Glossary

## Appendix 4 - Customer Information Bulletins

HOTLINE® Frequently Asked Questions	A4 - 2
General Advisement	A4 - 6
HOTLINE® - Specific Announcements	A4 - 7

smiths

1

Introduction /  
Specifications

2

Sub-Assemblies

3

Technical Description

4

Disassembly Procedures

5

Maintenance, Testing  
and Calibration

6

Troubleshooting

7

Spare Parts

8

Rounding Off

9

Appendix 1 -  
Circuits

10

Appendix 2 -  
PCB Layout

11

Appendix 3 -  
Symbols Glossary

12

Appendix 4 -  
Frequently Asked Questions  
Information Bulletins



**HOTLINE®**

Blood and  
Fluid Warmer

---

# HOTLINE® HL-90

## Blood and Fluid Warmer

The HOTLINE® HL-90 Blood and Fluid Warmer is designed for use with the HOTLINE® Warming Set to warm blood and IV fluids, and deliver them to the patient's intravenous access site at normo-thermic temperatures under gravity flow conditions.

By jacketing the sterile patient IV line with a layer of precisely controlled warmed recirculating solution, HOTLINE® provides active warming of the patient line all the way down to the patient connection, thus eliminating "patient line cool-down."

## Superior Performance

- The HOTLINE® innovative tubing design eliminates "patient line cool-down," and delivers warm intravenous fluids to patients

## Ease of Use

- Simple, 1-step plug-in disposable for fast setup and start
- A 2.4 m (8 foot) patient line allows convenient positioning of unit
- Requires 60 - 70% less priming volume (20 ml)
- Compatible with standard IV sets, infusion pumps and in-line hand pumps

## Features

- Integrated, highly effective design gives unparalleled ease of use
- Can be set up and operated in seconds
- Warmed Intravenous Fluid delivery at up to 4750 ml/hr
- Digital display of recirculating solution temperature
- Electronic circuitry continuously monitors recirculating solution temperature
- Green “Warming” operating LED
- Red fault indicator LEDs identify 3 common fault conditions
- Audible alarm indication
- Alarm test facility

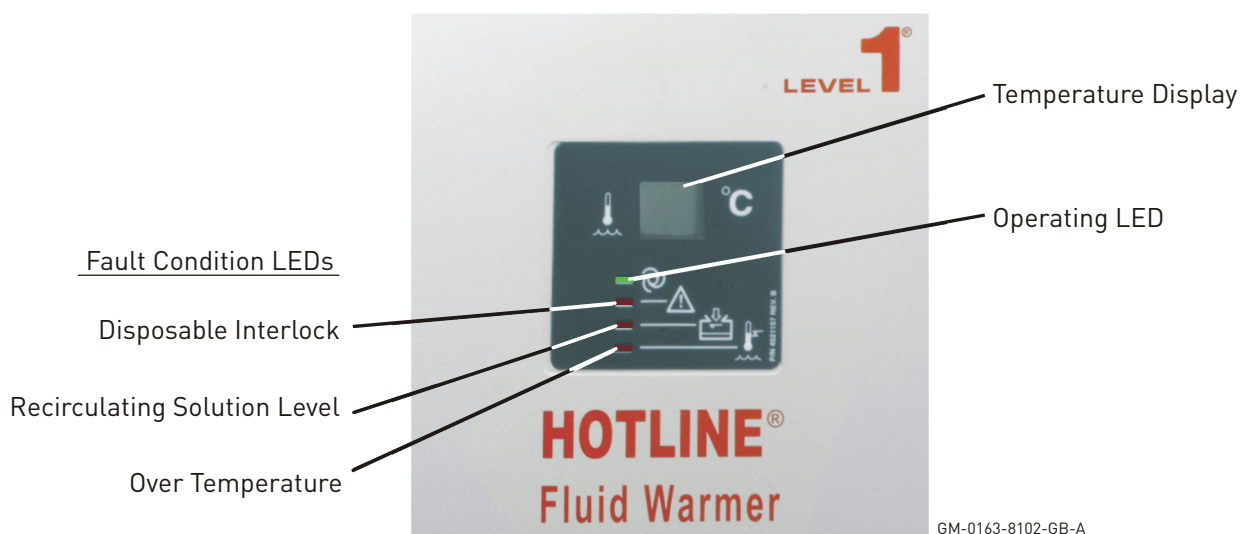

Figure 1 - 1: HOTLINE® Front Panel



## Specifications

Dimensions	inch	cm
Height	9.5	24.1
Length	8.3	21.0
Width	7.0	17.8

Weights	lbs	kg
Weight (dry)	7.6	3.5
Weight (full)	11.0	5.0
Weight (as Shipped)	7.95	3.6

Electrical	HL-90 US	HL-90 UK
Supply Voltage	115 V AC	230 V AC
Supply Current	3.0 A	1.5 A
Supply Frequency	50-60 Hz	50-60 Hz
Classification	Class 1	Class 1
Safety Rating	Type BF applied part	Type BF applied part
Power Cord	0.75mm x 3.6 m	0.75mm x 3.6 m

## Environmental

### Temperature

Operating Range	10°C — 45°C, 10 — 95% RH, (non-condensing)
Transport / Storage	-20°C — 70°C 5 — 95% RH, (non-condensing)

### Water Resistance

Enclosure Protection	IEC 60529, IP Code: IPX1
----------------------	--------------------------

## Miscellaneous

### Standards Compliance

Fluid Warmers	ASTM F2172-02
Product Safety	EN60601-1, UL2601-1
EMC	EN60601-1-2; FCC 47 CFR part 15, Class B

### Performance

Recirculating Solution temperature display will reach 37°C from ambient in about 4 minutes.

Operating Temp. Set Point	41.5°C ± 0.5°C
Over Temp. Set Point	42.6°C ± 0.5°C
Max Height on IV pole	107 cm (42 inch)
Recirculating Solution	1.4 litres Capacity

---

## Contra-indications

- Not Suitable for use in the presence of flammable anaesthetic mixtures with air or oxygen or with nitrous oxide.
- HOTLINE<sup>®</sup> disposables are not suitable for use with pressure devices generating over 300 mmHg.

smiths

1

Introduction /  
Specifications

2

Sub-Assemblies

3

Technical Description

4

Disassembly Procedures

5

Maintenance, Testing  
and Calibration

6

Troubleshooting

7

Spare Parts

8

Rounding Off

9

Appendix 1 -  
Circuits

10

Appendix 2 -  
PCB Layout

11

Appendix 3 -  
Symbols Glossary

12

Appendix 4 -  
Frequently Asked Questions  
Information Bulletins



**HOTLINE®**

Blood and  
Fluid Warmer

---

## Sub-assemblies

The principal sub-assemblies to be found in the HOTLINE® HL-90 are:

- The enclosure and chassis parts
- The recirculating solution path components
- The PCB and its mountings

These are detailed on the following pages.

# Enclosure (1)

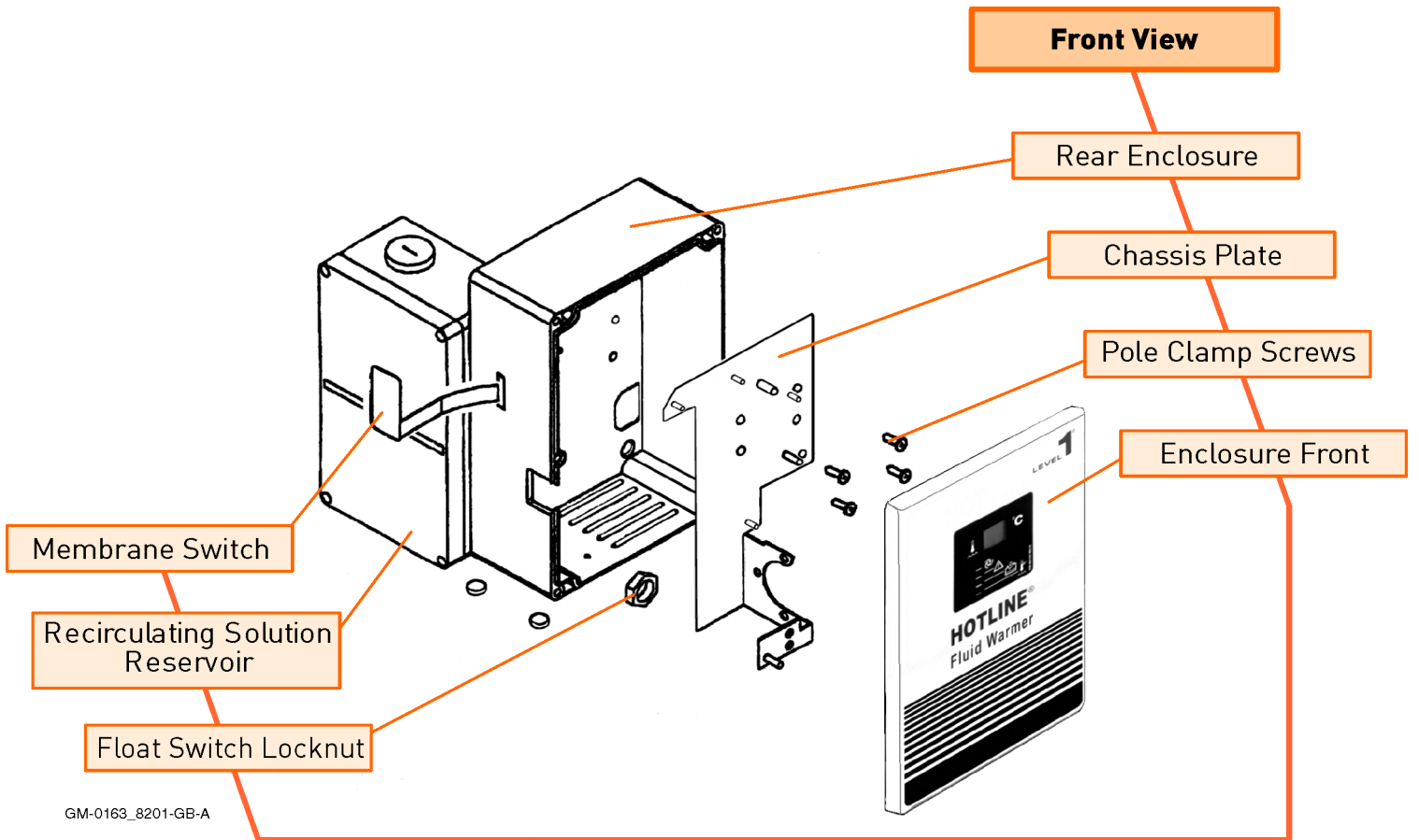

# Enclosure (2)

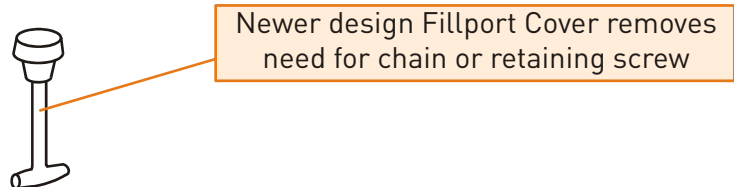
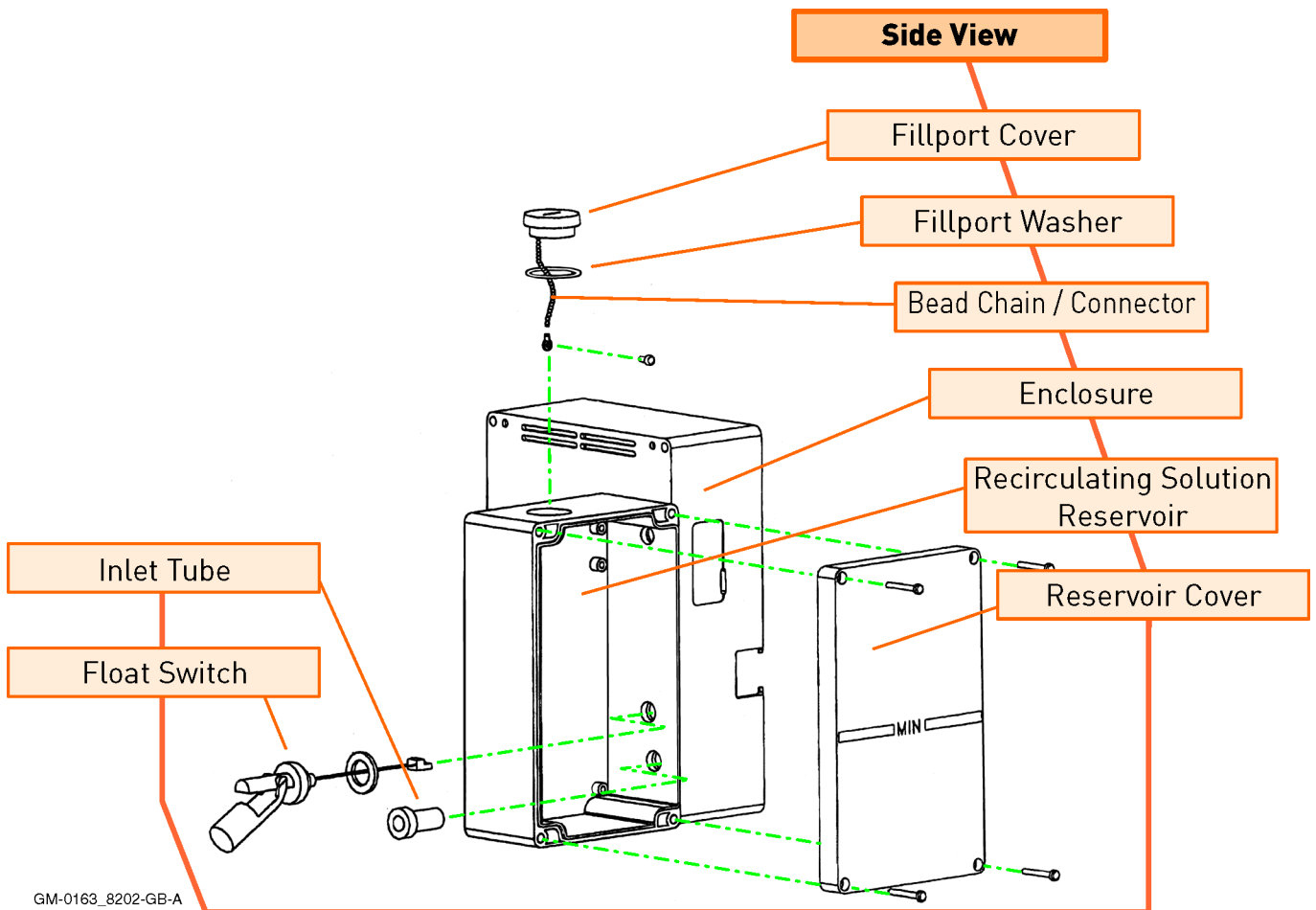

# Enclosure (3)

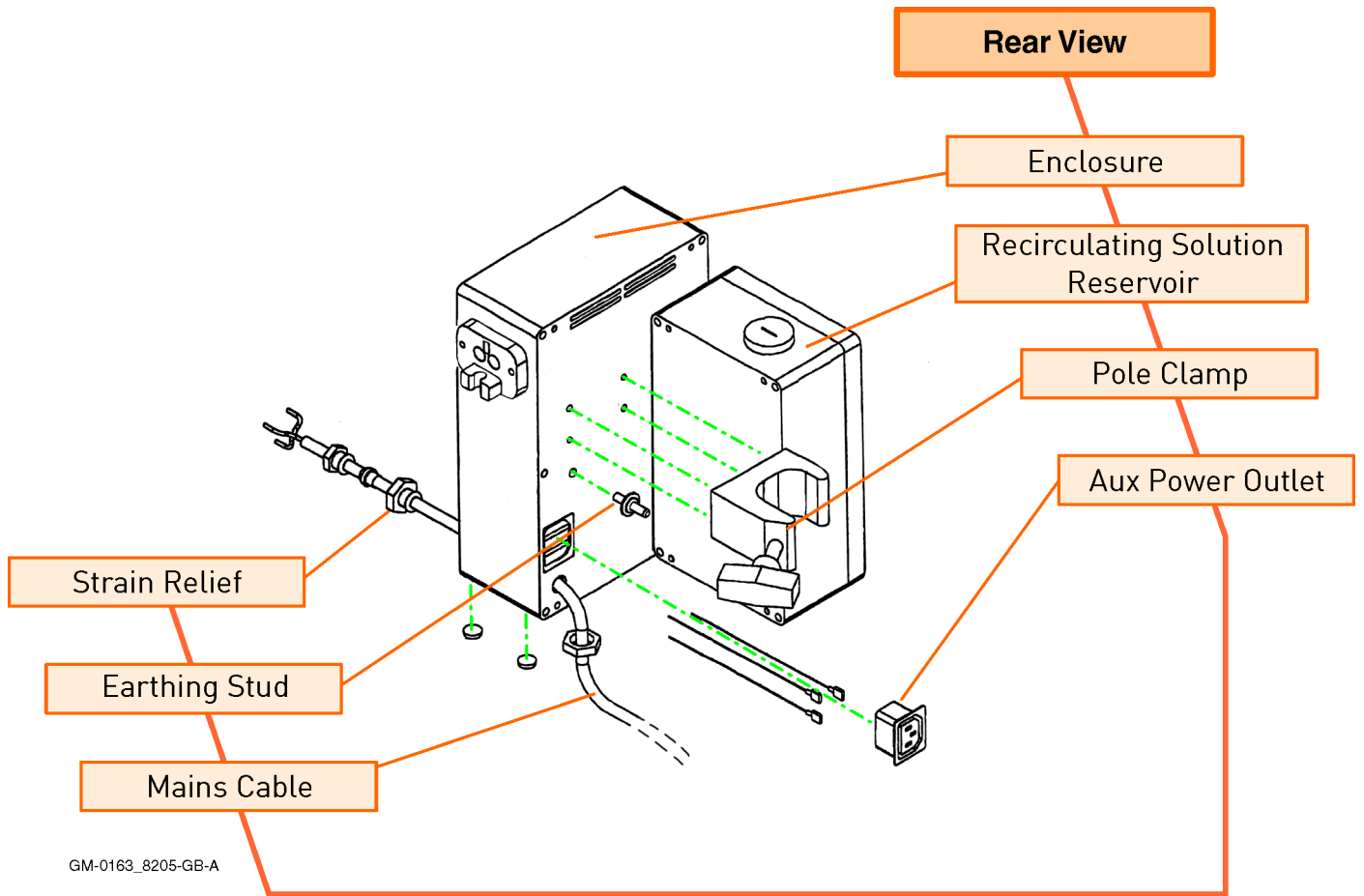



# Recirculating Solution Path

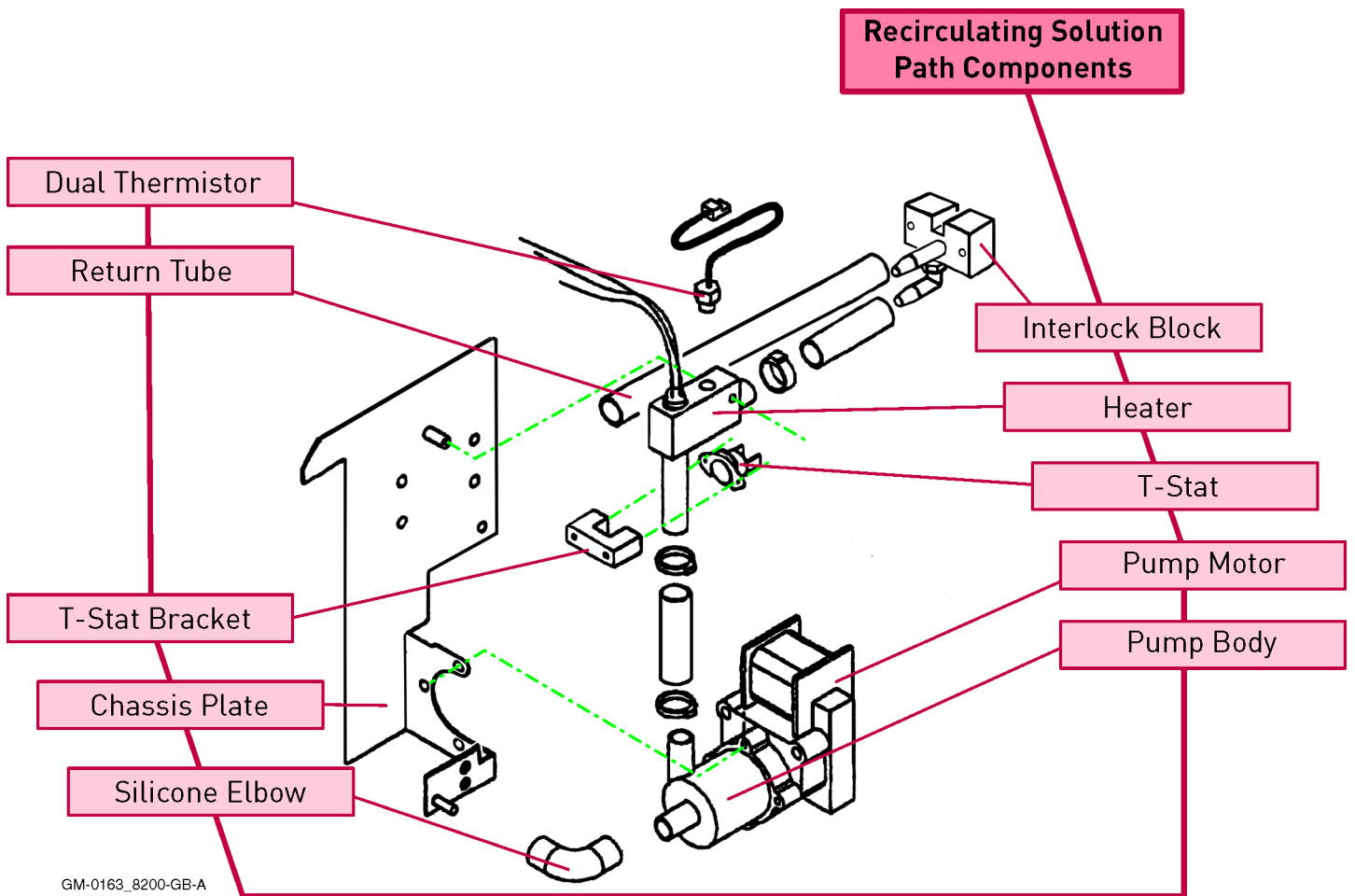

# Interlock Block

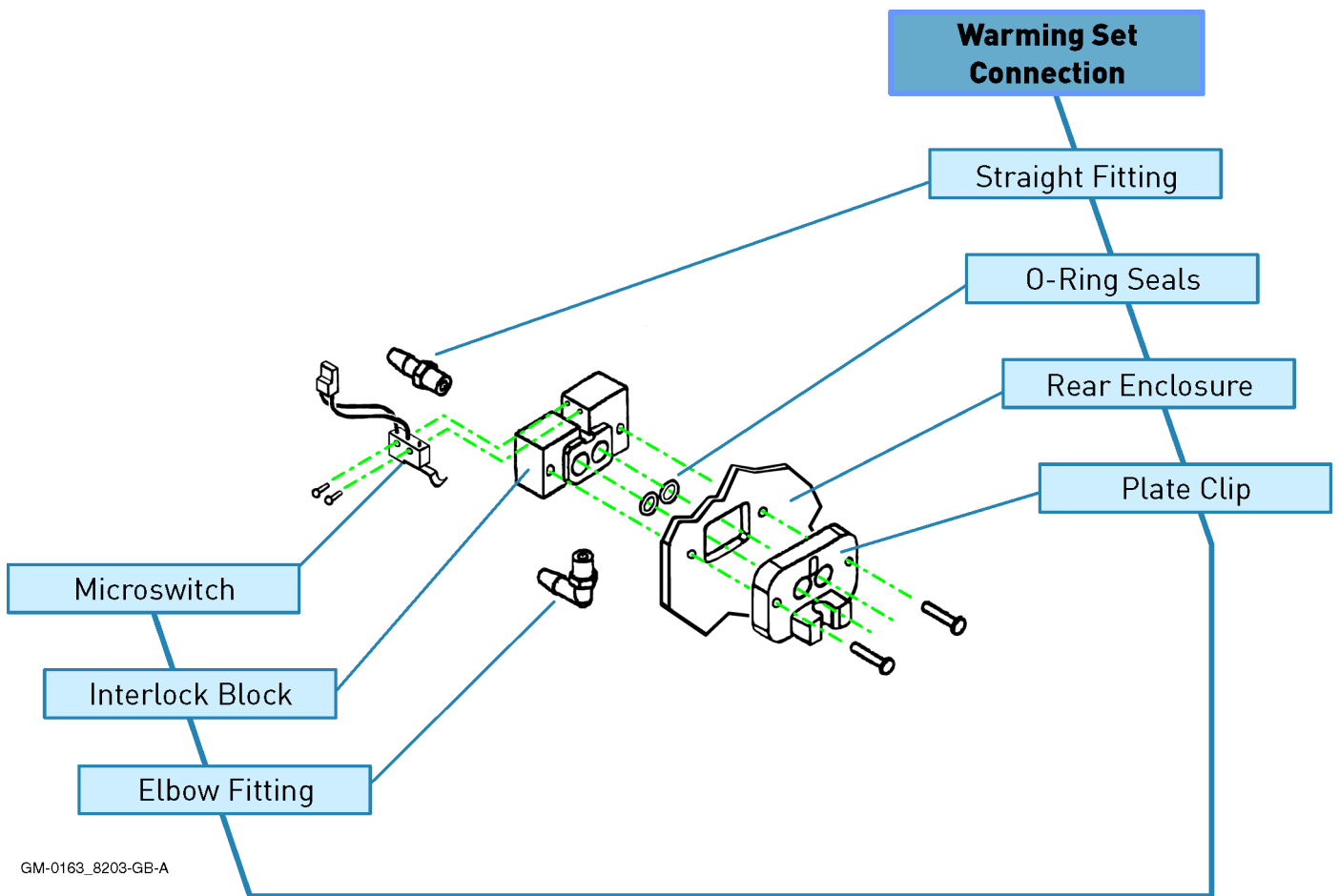

GM-0163\_8203-GB-A

# PCB Mounting

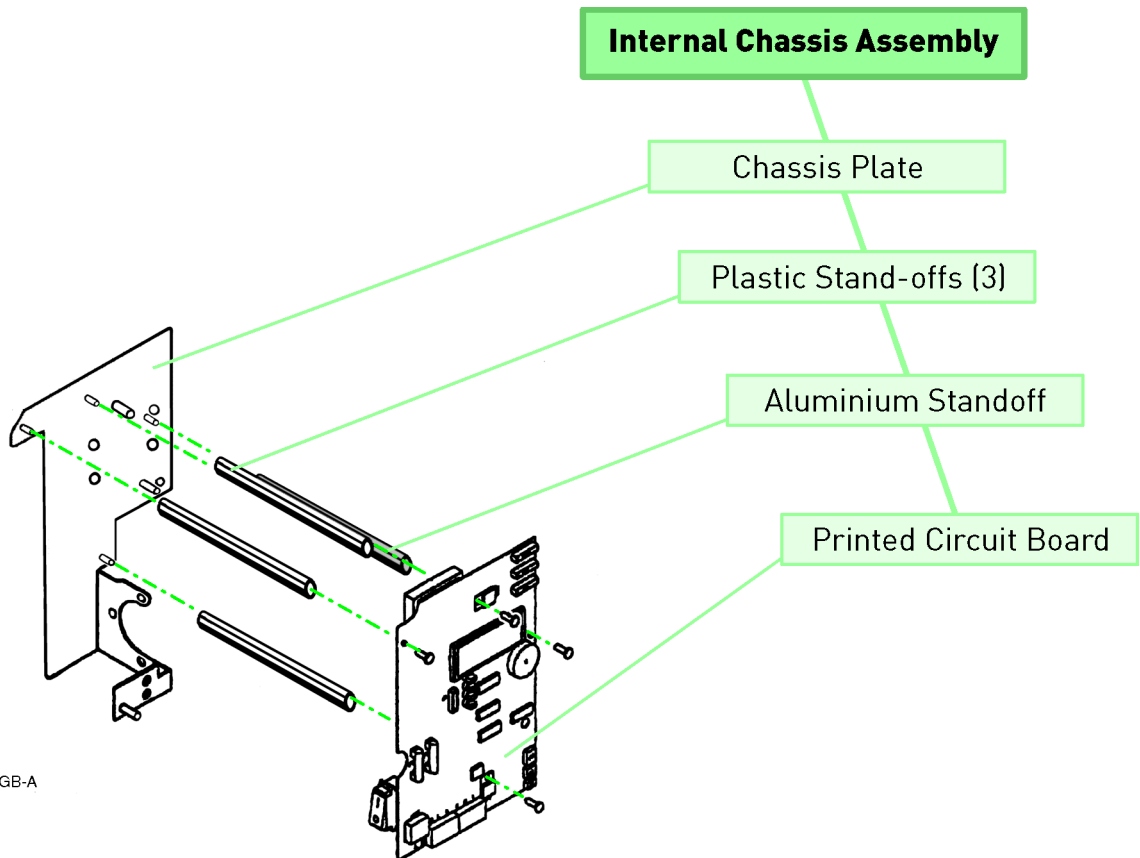

smiths

1

Introduction /  
Specifications

2

Sub-Assemblies

3

**Technical Description**

4

Disassembly Procedures

5

Maintenance, Testing  
and Calibration

6

Troubleshooting

7

Spare Parts

8

Rounding Off

9

Appendix 1 -  
Circuits

10

Appendix 2 -  
PCB Layout

11

Appendix 3 -  
Symbols Glossary

12

Appendix 4 -  
Frequently Asked Questions  
Information Bulletins



**HOTLINE®**

Blood and  
Fluid Warmer

---

# Technical Description

## General

The HOTLINE® employs a safe recirculating solution heating system, inherently free of hotspots, to actively warm the HOTLINE® **Blood and Fluid Warming Set** - a co-axial arrangement of warm fluid-filled jacket and sterile IV line. The primary temperature control circuit limits the recirculating solution to 42°C maximum. In the unlikely event of a malfunction of this circuit, a second watchdog circuit will visually and audibly alarm and stop pumping the recirculating solution if the temperature reaches 43°C.







The heater current is supplied via a thermal cutout, so in the case of a circulation failure, the heater will be protected against burn-out; the same cutout will act in the event of catastrophic breakdown of components in the HOTLINE® circuitry that prevents the alarm state from disengaging the heater.

These three levels of safety ensure that the IV Fluid in the HOTLINE® Fluid Warming Set is never exposed to any damaging or dangerous temperature while the unit is operating.

## Mechanical

The rear left-hand side of the unit is a reservoir, holding 1.4 litres of either distilled water or a disinfectant solution. This fluid will henceforth be referred to as recirculating solution. Do not confuse recirculating solution with the IV Fluid being dispensed to the patient.

## Controls and Indicators

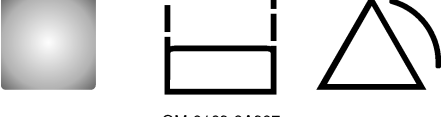
	<p>Shows the current temperature of the circulating warmed recirculating solution.</p>
	<p>This steady GREEN indicator illuminates when power is ON and the Warming Set is correctly installed. The recirculating solution is being warmed and circulated.</p>
	<p>This flashing RED indicator with audible alarm shows that warming and circulating has been stopped because the Warming Set is not fitted properly. Reattach the Warming Set and continue.</p>
	<p>This flashing RED indicator with audible alarm shows that warming and circulating has stopped because there is not enough recirculating solution in the unit to operate the float switch. Refill, and continue.</p>
	<p>This flashing RED indicator with alarm shows that warming and circulating has been stopped because the recirculating solution reached a temperature above the set point. The unit must be removed from service, and repairs effected before returning to service.</p>
<p><b>SIDE PANEL BUTTON</b></p>	
	<p>Simulates triggering of the Over Temperature watchdog alarm for testing.</p>
<p><b>SIDE PANEL BUTTON</b></p>	
	<p>General Alarm Test Simulates triggering of all alarms for testing.</p>

---

## Mechanical (contd)

The outer face of the reservoir is transparent so the recirculating solution level and flow can both be observed. A float switch is fitted in the tank, so that the unit cannot operate if there is insufficient recirculating solution to properly circulate. Recirculating solution is drawn from the bottom of the reservoir, via a silicone rubber elbow into a centrifugal pump driven by a 60VA synchronous electric motor in the main enclosure.

The pump outlet is vertically upwards, and feeds into the heater assembly via another short length of silicone rubber piping. The heater assembly is a solid cast L-shaped unit that, in the vertical leg, incorporates a 300 watt heater element, able to warm the recirculating solution from room temperature to 37°C in 4 minutes. In the horizontal leg of the heater assembly, a special dual thermistor unit is submerged in the flow, to monitor and control the warmed recirculating solution temperature.

Clamped to the external surface of the heater assembly is the T - Stat, a thermally-operated bi-metallic cutout that breaks the circuit at temperatures above 50°C. The cutout only self-resets when the temperature has dropped significantly (10°C - 15°C) below its nominal operating temperature.

The warmed recirculating solution leaving the heater assembly now enters the interlock block, at the top right-hand side of the HOTLINE®. This interfaces to the Fluid Warming Set that contains the sterile line for the patient's IV fluid. The Fluid Warming Set needs to be in place so as to operate a microswitch that would otherwise raise an alarm and cut off the pump. Running back from the interlock block is the recirculating solution return line, which leads directly through the rear of the main enclosure and into the top of the reservoir.

## Electrical Power Circuits

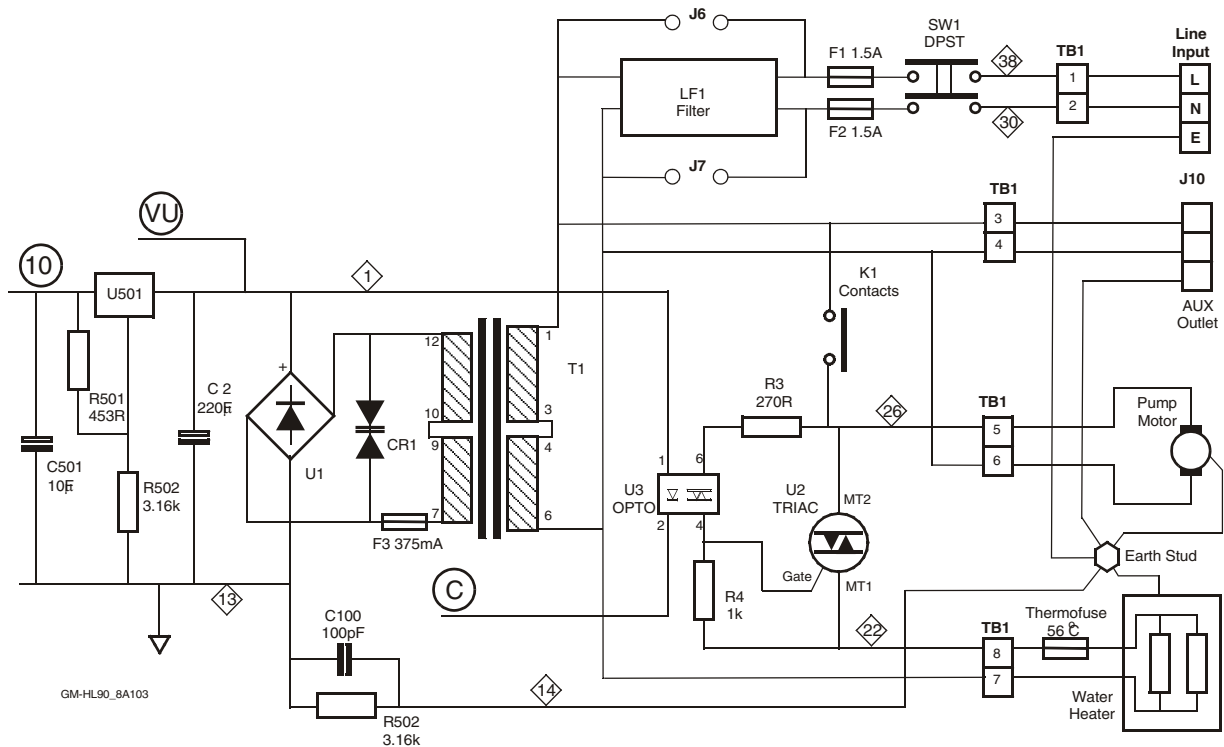

Figure 3 - 1: HOTLINE® Power Circuits

Power circuitry is conventional, and is constructed on the PCB. There are three fuses, F1 and F2 (both 1.5A) for the Mains input, and F3 (375 mA) for the low voltage circuits. F3 is wire-ended device, soldered into place at the top edge of the PCB.

On the Mains side, the power normally passes through a line filter to reduce susceptibility to interference (this filter is not always required for domestic US units.) The pump motor is switched by a PCB-mounted relay K1, and the heater element is controlled by a triac. The heater can only be energised when the pump is powered on, since without recirculating solution flow, the heater element would quickly overheat.

The heater triac is triggered via an optical isolator, and all the Mains voltage circuits are physically distanced from the low-voltage circuits for safety reasons. The low-voltage control circuits are



derived from a conventional step-down transformer. After rectification and smoothing, the supply is regulated to a nominal 10 volts by U501, an LM317T integrated regulator. Resistors R501 and R502 set the exact output voltage level.

**NOTE:** The **HOTLINE®** is **NOT** a Class 2 double-insulated device, and must be connected with a good earth connection to ensure patient and operator safety.

## Control Circuit

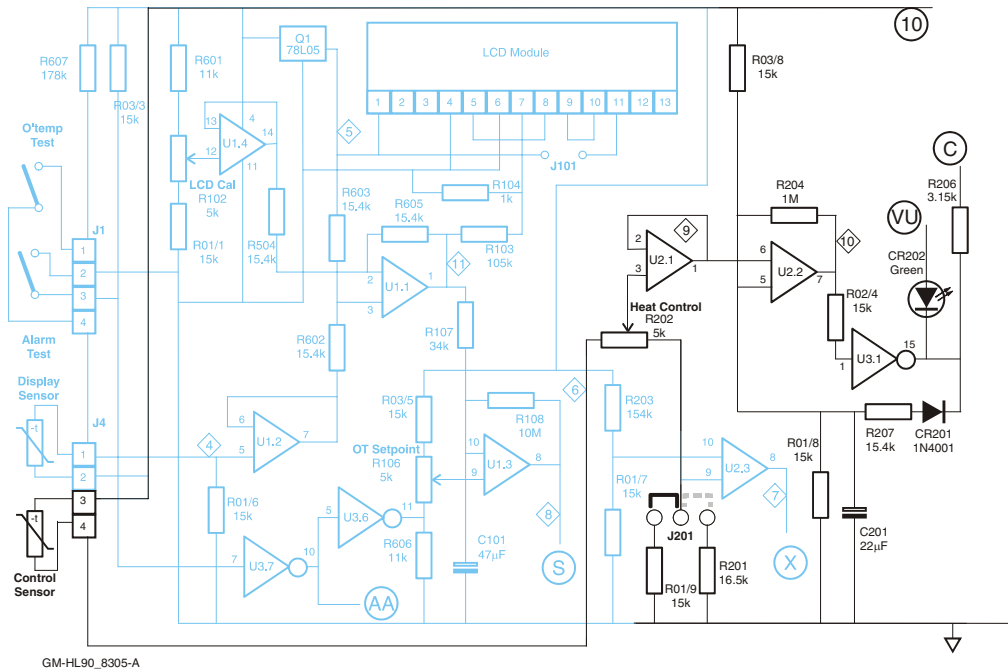

Figure 3 - 2: **HOTLINE®** Temperature Control Circuits

The control sensor is one of a “siamese twin” pair of thermistors submerged in the recirculating solution flow as it leaves the heater. At normal operating temperatures, the thermistors each have a resistance of about 15k, and this decreases roughly linearly with increasing temperature.

---

As a result, the current through the chain [*control thermistor - R202 - R01/9*] is roughly proportional to the recirculating solution temperature, and thus, so is the voltage sample at R202 slider. This is buffered by U2.1, part of an LP324N quad op-amp, and passed to U2.2, which is configured as a comparator. At pin 5 of U2.2, a reference voltage of about 5 volts is created by the voltage divider resistors R03/8 and R01/8.

If the temperature-dependent sample at pin 6 is less than the reference level set at pin 5, then pin 7 will go high, which switches on the darlington driver U3.1, and so turning on the opto/triac/ heater combination. However, this also grounds R207 via CR201, which starts discharging C201, and so reducing the reference voltage at U2.2/5. Unless the recirculating solution is very cold, the reference voltage will soon dip below the sample voltage, so turning off the heater circuit.

As soon as U3.1 turns off, C201 can start recharging to 5 volts, and at some point the reference voltage overtakes the sample voltage, and the heater turns on again, repeating the cycle. R204 provides a modest amount of positive feedback, ensuring that the switch transitions are snap-action.

You can see that the repetition rate of the circuit depends both on the RC time constants around C201, and also on the temperature of the recirculating solution in the reservoir. If this is still some distance from the desired temperature, the sampled voltage will “sag” very quickly when the heater turns off, and fresh cold recirculating solution is pumped through the heater unit.

If, however, the HOTLINE® has been running some while, all the recirculating solution in the circulation loop will be at, or close to, the desired temperature, so the sample voltage will hardly move at all.

## Digital Display

The temperature control thermistor is one of a pair, siamesed together in the heater housing. The other of these provides a user display of the recirculating solution temperature and, as we will see later, protection in case of failure by the first thermistor.

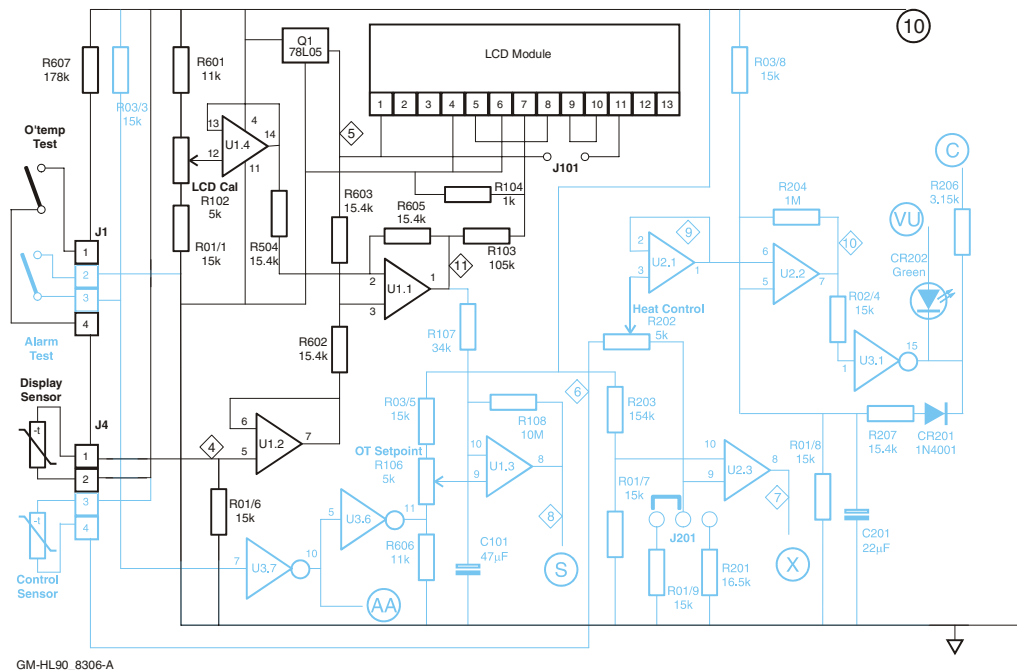

Figure 3 - 3: HOTLINE® Temperature Monitoring Circuits

The output from the display sensor thermistor is buffered by U1.2, another LP324 quad op-amp device. It passes to U1.1, which is a summing amplifier, combining the sensed voltage with the buffered output from U1.4. This allows a degree of offset, determined by R102, to be introduced for calibration purposes.

The buffered and calibrated voltage is scaled by R103/R104, and presented to the digital LCD millivolt-meter module for display. The window in the front case allows two digits to be seen by the user, although the third digit (tenths of a degree) may be seen by the technician when the case front is removed.

## Thermistor Loss

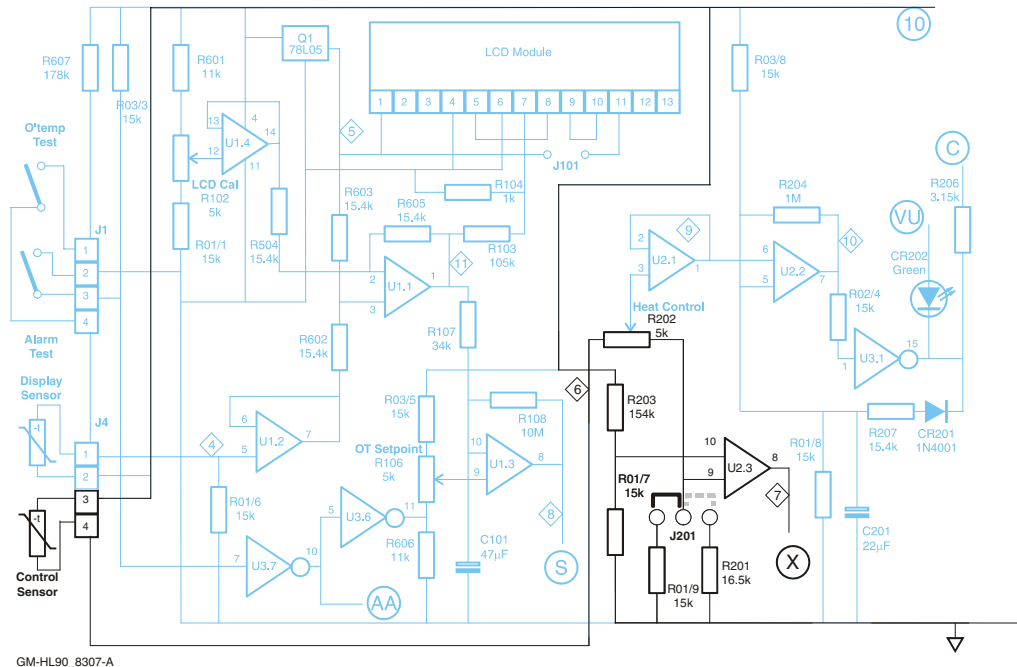

Figure 3 - 4: HOTLINE® Thermistor Loss Monitoring

Since both control and display thermistors are NTC devices, their resistance DECREASES with increasing temperature. This means that if the thermistor or its wiring were damaged somehow, an open circuit sensor would potentially be a dangerous situation. The infinitely HIGH resistance of an open circuit would be interpreted as a very LOW temperature, and so the HOTLINE® would fail with the heater powered permanently ON.

To prevent this, U2.3 detects that there is a reasonable voltage being fed to the temperature controller circuit. If the thermistor circuit ever achieved an effective resistance of some 150K or more, then U2.3 will turn on sending signal X high. Needless to say, there is no place on earth cold enough to get this much resistance from the thermistor through natural causes!

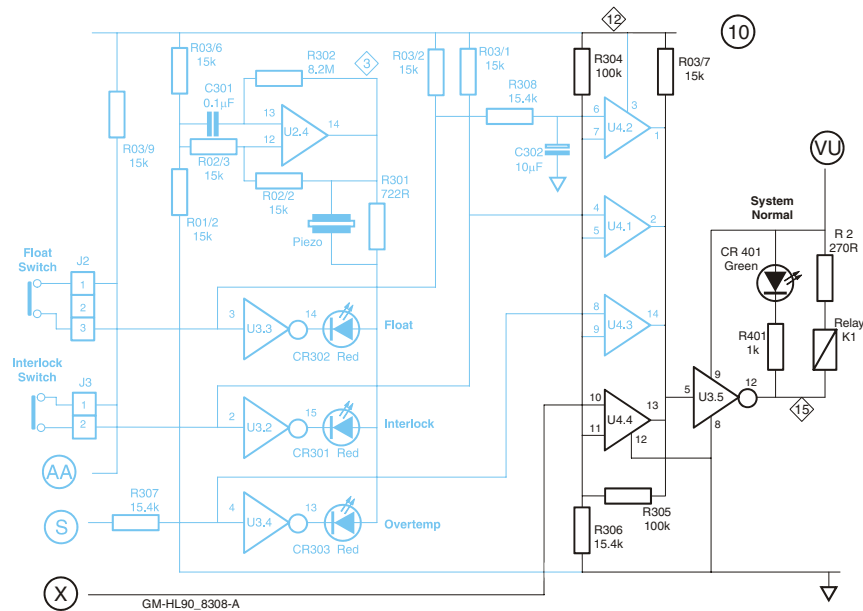

Figure 3 - 5: HOTLINE® Thermistor Loss Alarm

Following signal **X** onto the next page, we see that it reaches U4.4. U4 is an LP339 - a low-power version of an industry standard quad comparator with open-collector outputs. Taking signal **X** high turns on U4.4's output, which starves darlington driver U3.5's input of current. This was being held on by R03/7, but now it turns off, so cutting off the relay K1, which in turn removes power from the pump motor and heater mains circuits, thereby rendering the HOTLINE® (and any patients it may be attached to) safe.

This arrangement of open-collector devices feeding a common input effectively creates an OR-gate, allowing multiple inputs to control the output relay.

## Over Temperature Alarm

Earlier, we looked at how the display was generated from the second thermistor in the siamesed package. There is another good reason for having a double thermistor arrangement - as safety watchdog in case of failure.

In this part of the circuit, we take the buffered and calibrated display signal through R107, and using another quarter of the op-amp U1, compare it to a pre-selected over temperature set point, set by R106. If the temperature has got too warm, perhaps because the primary thermistor has given up, then signal **S** will be activated.

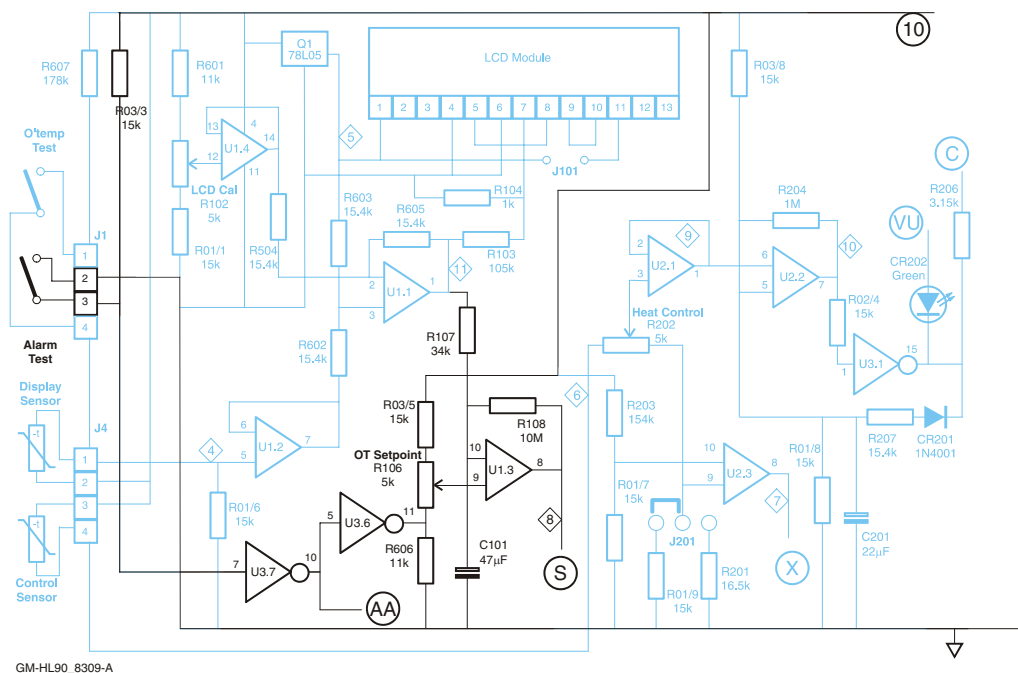

Figure 3 - 6: **HOTLINE®** Over Temperature Monitoring

Since failure of this part of the circuit could be quite catastrophic, there are two separate methods of verifying that it is working OK.

Pressing the Alarm Test button artificially lowers the set point by making U3.6 short out R606. Since the set point is lowered to below room temperature, this should set off the alarm whatever the actual fluid temperature.

The second test mechanism is operated by the Over Temperature Alarm Test button. This overrides the display thermistor to fake an over temperature situation. You should see the display rise to an artificially simulated temperature of 43°C - 44°C. Because of the delay (C101 and R107) you need to hold the button for 2 - 3 seconds to activate the test.

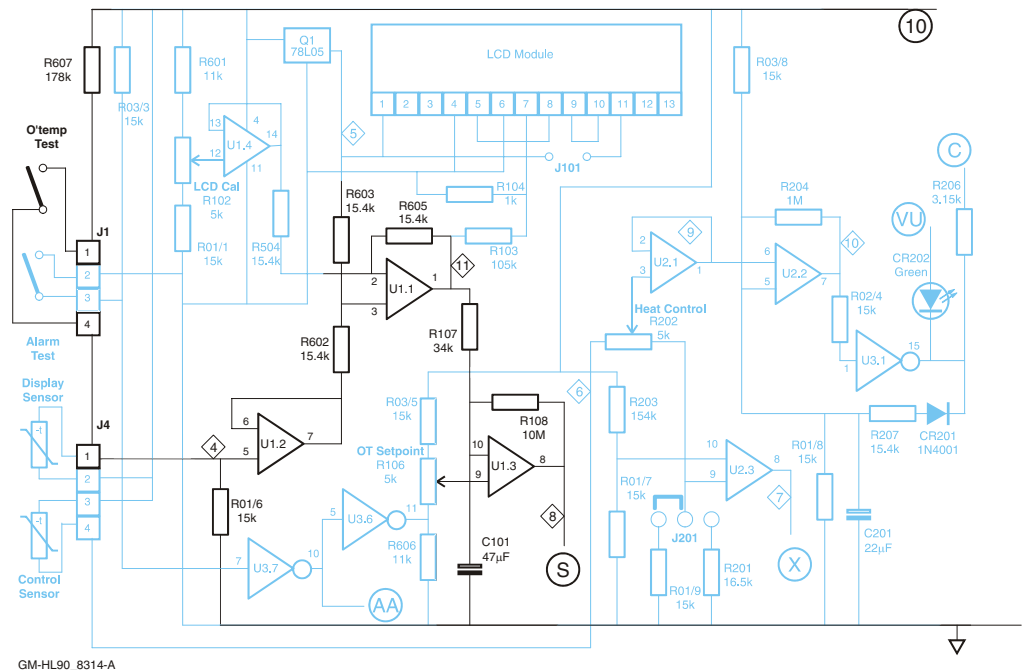

Figure 3 - 7: HOTLINE® Over Temperature Alarm Test

Signal S operates in much the same way as signal X did previously, using U4.3 to cut off the pump and heater circuits. In addition however, there is a LED, driven by U3.4, visible from the case exterior to warn the operator that this fault situation has occurred.

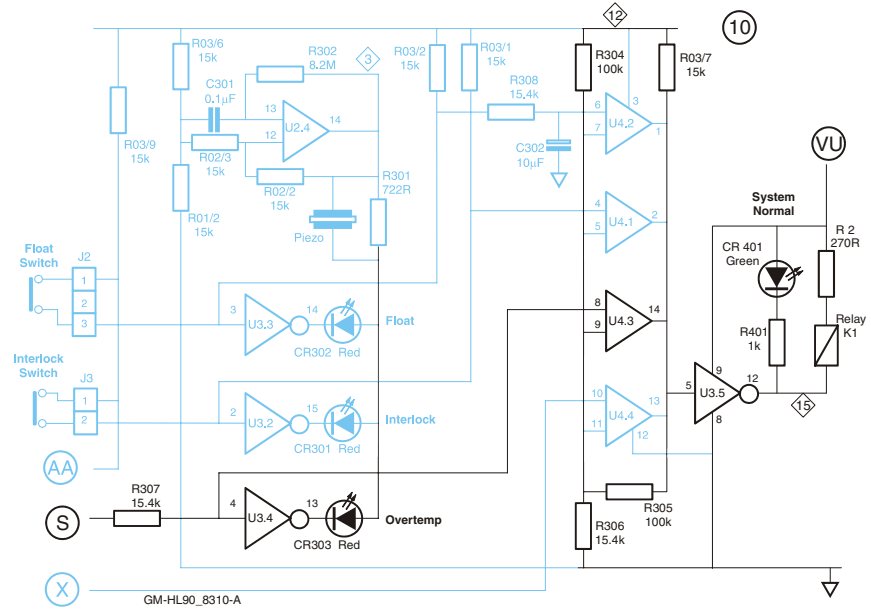

Figure 3 - 8: HOTLINE® Over Temperature Alarm

## Flasher

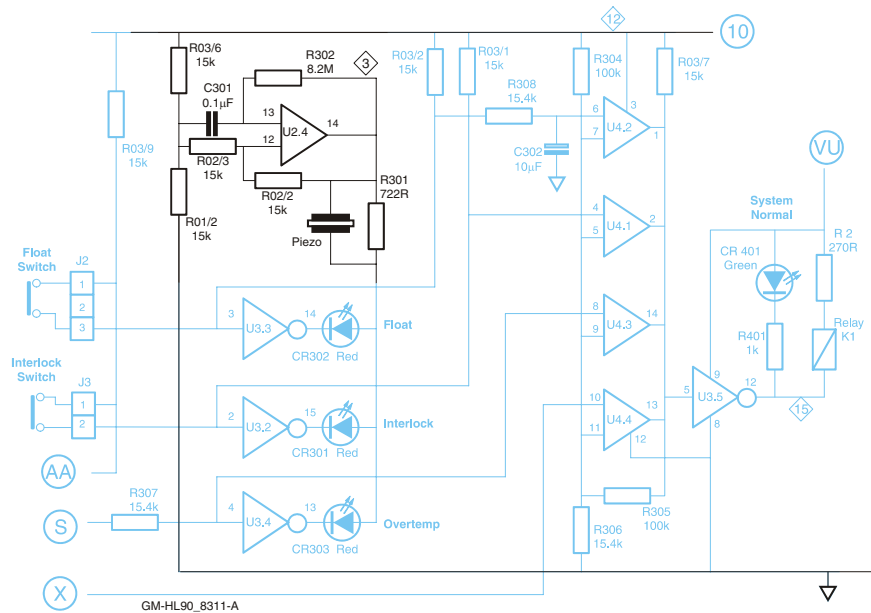

Figure 3 - 9: HOTLINE® Alarm Flasher



---

The alarm LED does not return directly to the positive rail, as you might expect. Instead it gets its power from U2.4, which is configured as a low-frequency square-wave oscillator. This means that the LED can only light up when U2.4's output is high - so it flashes on and off to attract attention.

Whenever the LED is ON the piezo-sounder is powered by the volt-drop across the LED's current-limiting resistor R301, so it beeps in synchronism with the flashing of the alarm LED.

*Exercise: If more than one alarm happened at once, then two or more LEDs would be flashed by this circuit. The extra current drain should increase the volt-drop across R301, so you would expect the Piezo-sounder to increase in power and volume for every extra alarm condition.*

## QUESTION...

*Guess how much percentage increase in beep volume results from ALL alarms simultaneously, compared to a single alarm?*

*Now try to justify your answer!*

## Interlock Alarm

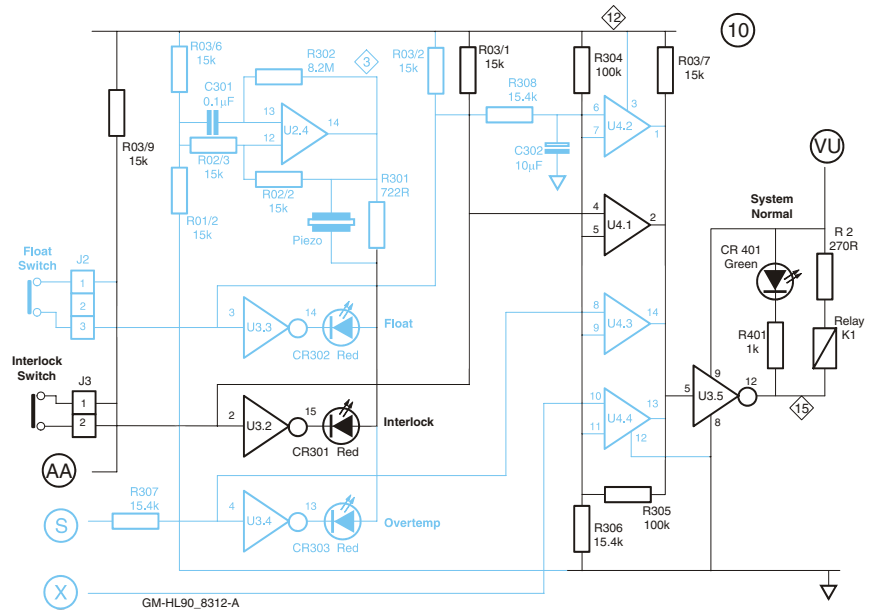

Figure 3 - 10: HOTLINE® Warming Set Interlock Alarm

The interlock switch is a simple microswitch which is operated by the insertion of the warming set into the twin socket. If you were to switch the pump on with no warming set connected, the results would not be catastrophic, nor particularly dangerous, but they could be awfully messy!

Therefore, if the Interlock Switch is not made, the pump (and heater) will not run. The flashing LED lets you know why the HOTLINE® is refusing to co-operate.

This part of the circuit has a fail-safe action that might mislead you if you're faultfinding. U03.2 is kept turned on by the pull-up resistor R03/1 so that if there is a fault in the interlock switch off-board wiring, or the J2 connector isn't fully connected, the alarm is defaulted ON. You need a good continuous circuit through J2 to allow U3.7 to pull U03.2 low and turn the alarm state off.

U3.7 is the Alarm Test circuit; if there is a fault in the alarm test switch, nothing happens except the unit will be unable to test its alarms. The integrity of the alarm itself would not be compromised by alarm test switch failure.

## Recirculating Solution Level Alarm

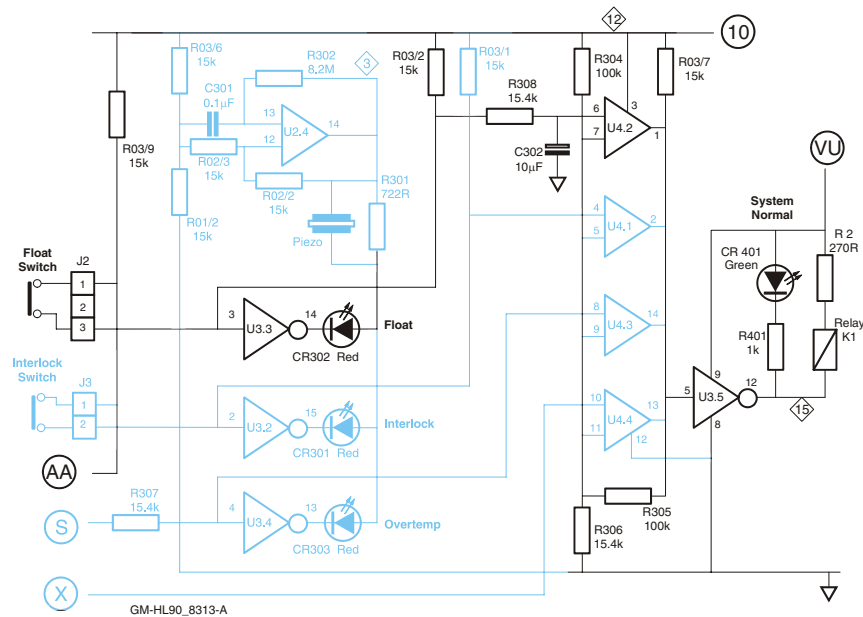
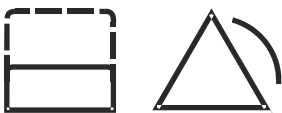

Figure 3 - 11: *HOTLINE*<sup>®</sup> Low recirculating solution Level Alarm

The recirculating solution level alarm is an almost exact copy of the interlock alarm arrangements. The starting point for this, however, is a float switch mounted in the reservoir. The one significant difference is that the interlock switch acts instantaneously, whereas the float switch has a time delay element (R308 and C302) to reduce false alarms due to recirculating solution just sloshing about.



Both interlock and recirculating solution level alarms will be exercised by signal **AA**, which is derived from the general Alarm Test button (left) mentioned earlier.

## Answer to the page 28 Puzzler

As you probably guessed, it's a bit of a trick question. The fact is that it really does look like the volume should increase, but this is apparently not the case. So what's going on here?

Well, we kind of helped you to think that the current in R301 must increase with every extra LED, but this isn't necessarily so. All this current has to come from the Op-amp U2.4, type number LP324N, which is described by its makers as a MICROPOWER device.

For this reason, its ability to source current is less than you might have thought. You can see that from this graph:

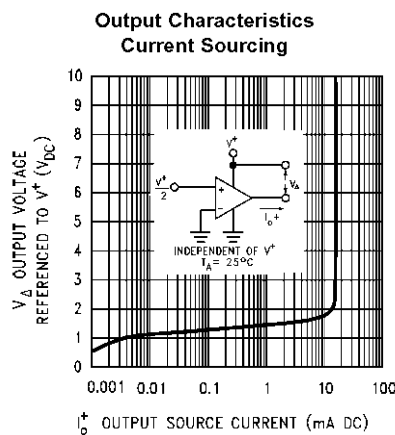

GM-HL90\_8315-GB-A  
Source: National Semiconductor

00856231

Not wanting to bore you, we won't figure out all the voltdrops across all the various components, but you can see that if the first LED is taking 12 - 15 mA (a reasonable amount), then the Op-amp is already pretty much in saturation, and there is no more current available, no matter how many LEDs you light up.

So maybe the question should have been, did the first LED get any dimmer as the second and third got added?

smiths

1

Introduction /  
Specifications

2

Sub-Assemblies

3

Technical Description

4

Disassembly Procedures

5

Maintenance, Testing  
and Calibration

6

Troubleshooting

7

Spare Parts

8

Rounding Off

9

Appendix 1 -  
Circuits

10

Appendix 2 -  
PCB Layout

11

Appendix 3 -  
Symbols Glossary

12

Appendix 4 -  
Frequently Asked Questions  
Information Bulletins



**HOTLINE®**

Blood and  
Fluid Warmer

---

## Tools you will need

- Needle-nose pliers
- Philips head screwdriver
- Small straight head screwdriver
- $\frac{1}{8}$  inch A/F Allen key (hex wrench)
- $\frac{7}{8}$  inch A/F open ended spanner (wrench)
- $\frac{3}{4}$  inch A/F open ended spanner (wrench)
- $\frac{7}{16}$  inch A/F open ended spanner (wrench)
- $\frac{3}{8}$  inch A/F deep box spanner OR socket and extension drive
- $\frac{1}{4}$  inch A/F open ended spanner (wrench)
- 10 mm A/F open ended spanner (wrench)

### Optional

- Oetiker Clenching Tool  
(This will be needed if it is intended to replace the heater element or the pump/motor combination)

# Disassembly

## Step 1: Open the case

**WARNING:** Ensure that the **HOTLINE®** is disconnected from the Mains power. If the **HOTLINE®** has been recently used, be aware that some interior components may be hot.

Place the **HOTLINE®** on a firm surface at a convenient height. Loosen the front cover screws. Early models have six screws, facing forward. These screws are tethered to the front panel, so it is neither necessary or desirable to completely remove them.



GM-0163\_8401-GB-A

Figure 4 - 1: The underneath view of a **HOTLINE®** with the newer (one-part) case.

Later models have only two front cover retaining screws, located under the unit. Again, it is not necessary to completely remove these screws.



*Figure 4 - 2: Loosen, but don't completely remove these screws*

**! WARNING: STATIC-SENSITIVE COMPONENTS.** Ensure that proper antistatic precautions are taken before attempting any procedure that requires handling the PCB.



## Step 2: Remove the PCB

Remove connectors J2, J3, J4 by gently pulling on them.

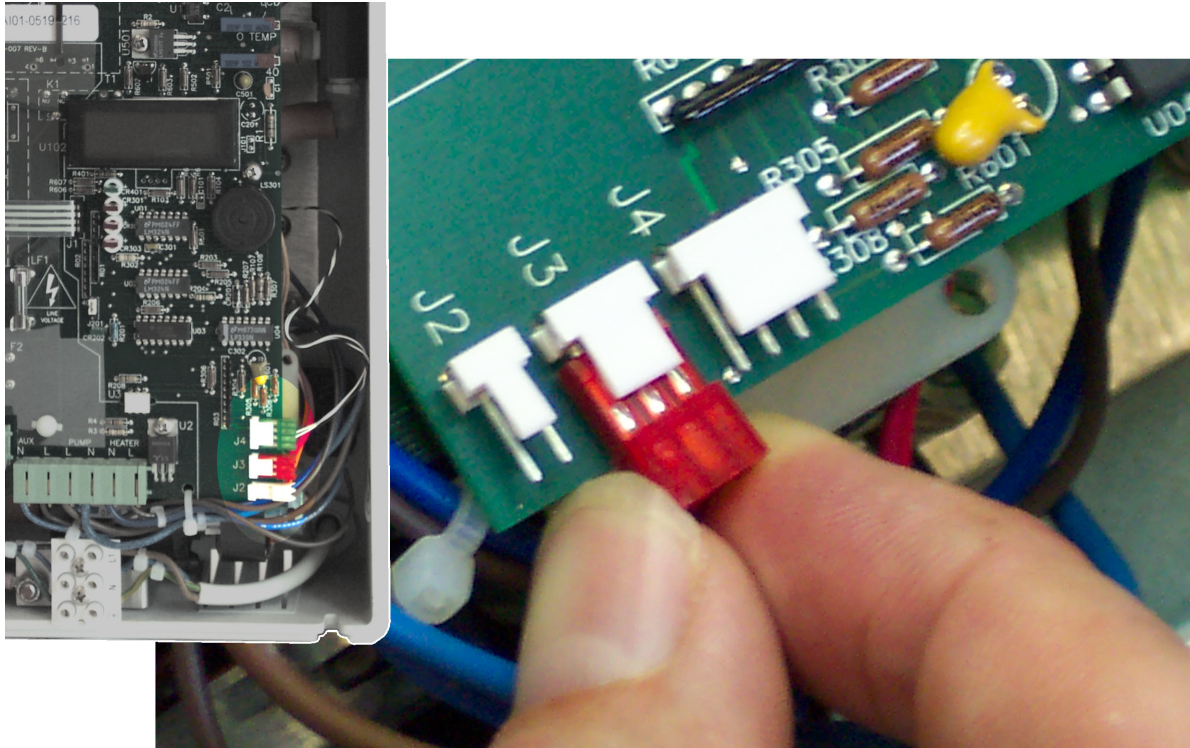

GM\_0163\_8404-GB-A

*Figure 4 - 3: Disconnecting J3*

Do not pull on the wiring, but grasp the connector body itself. It may be easier to use the needle-nose pliers.

Remove the membrane switch ribbon connection from J1 by gently pulling it.

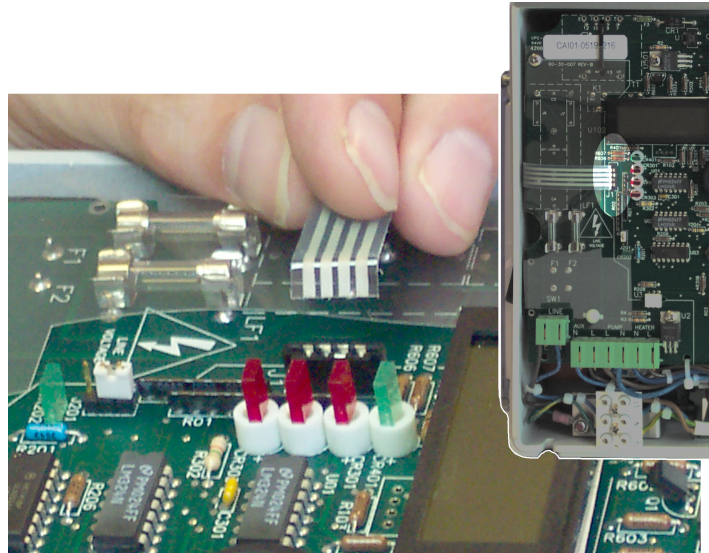

GM-0163\_8405-GB-A

Figure 4 - 4: Membrane Switch Connector

Now release the mains input cable from the “Lego brick” terminals at the bottom front of the case.

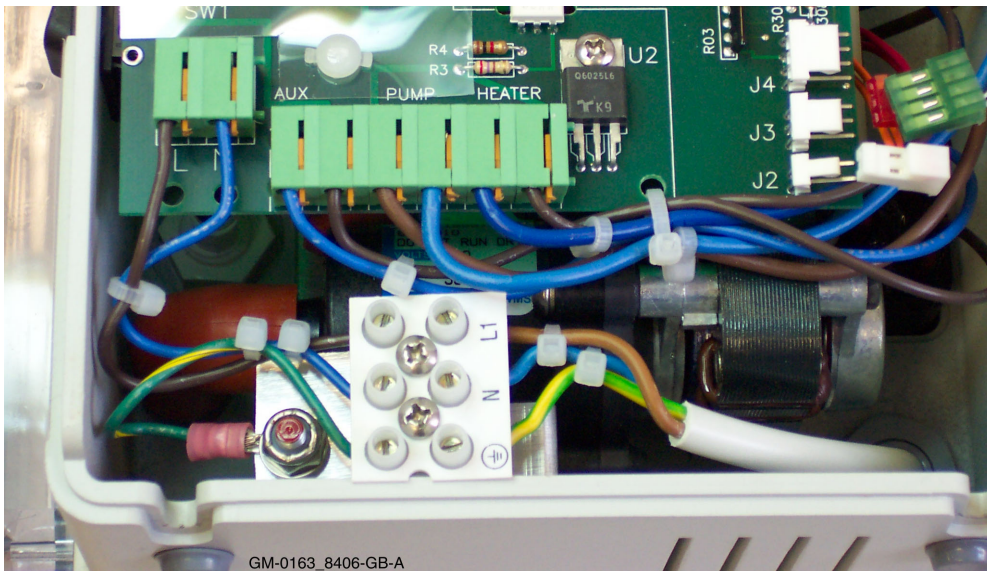

GM-0163\_8406-GB-A

Figure 4 - 5: Mains Cable Input Terminals

Remove the eight wires from the terminals along the bottom edge of the PCB. To release the wires, each terminal's orange tab must be pressed into the terminal body with pliers.

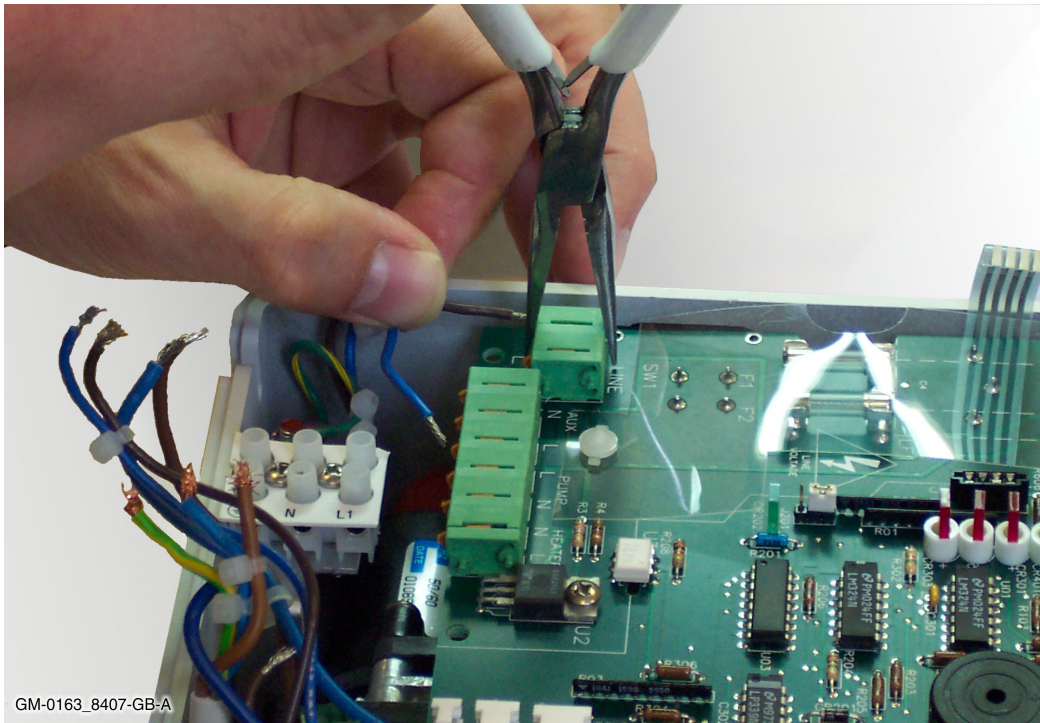

*Figure 4 - 6: Opening the terminal by squeezing the orange release tab*

Alternatively, the tabs may be manipulated with a small straight screwdriver through the slot on the terminal's top surface.

Remove the four screws indicated.

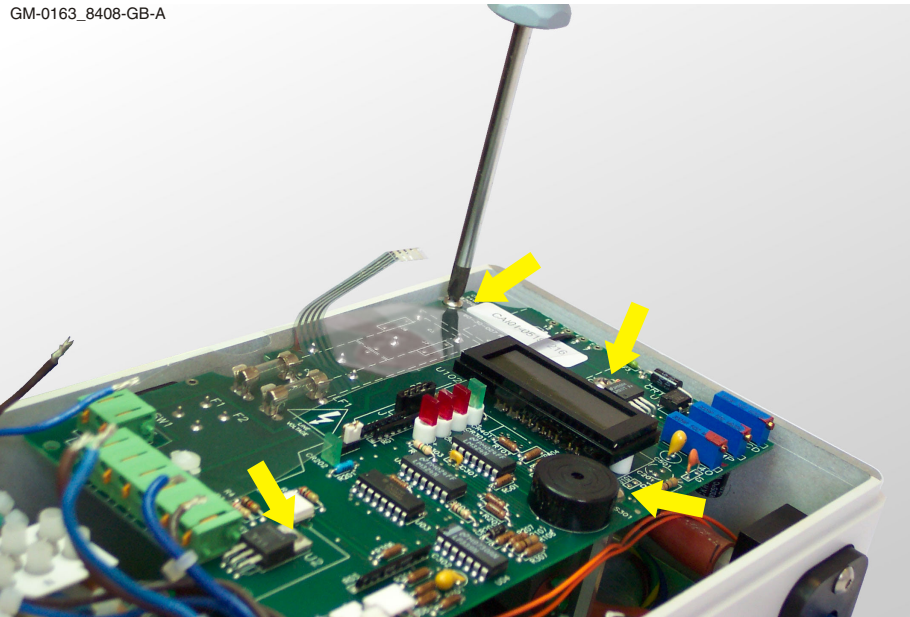

Figure 4 - 7: PCB Mounting Points

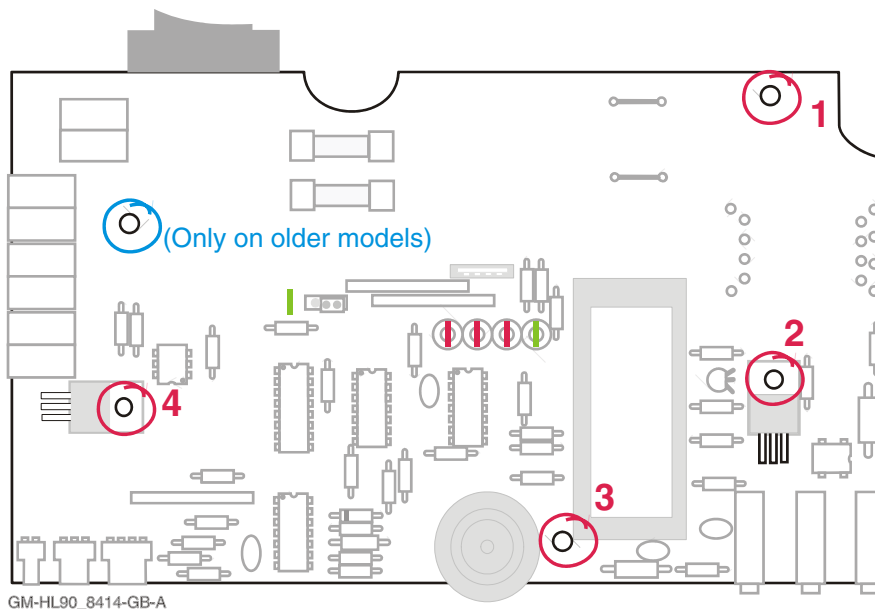

Figure 4 - 8: Older versions have an additional fixing screw, making five in all.

## Step 3: Release the Earth Stud

With the PCB removed, you will be able to see the external Earthing Stud which is attached to the chassis and passes out through the rear of the case. Undo the 10mm nut holding it in place, using a spanner on the outside to prevent rotation. Undo the 3/8 inch nut and take off the earth conductors from the internal Earthing Star Point.

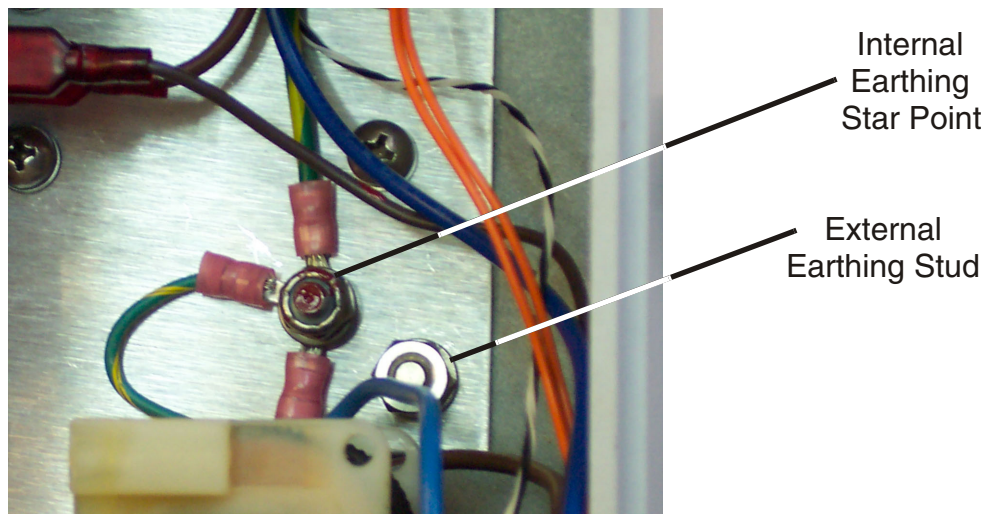

Figure 4 - 9: Earthing Arrangements

Notice the order of assembly on this terminal: the crinkle washers are not there just to prevent unscheduled vibrational disassembly, but also to cut into any corrosion on the ring terminations and ensure good continuity.

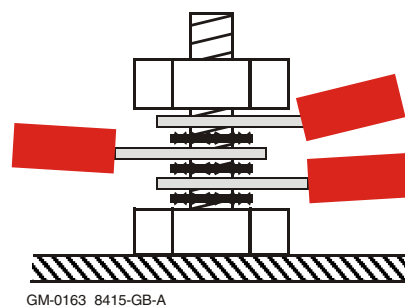

Figure 4 - 10: Use of Crinkle Washers

## Step 4: The Recirculating Solution Return Pipe

The recirculating solution return pipe emerges straight from the back of the interlock block and crosses the enclosure to the left-hand side, where it passes into the reservoir.

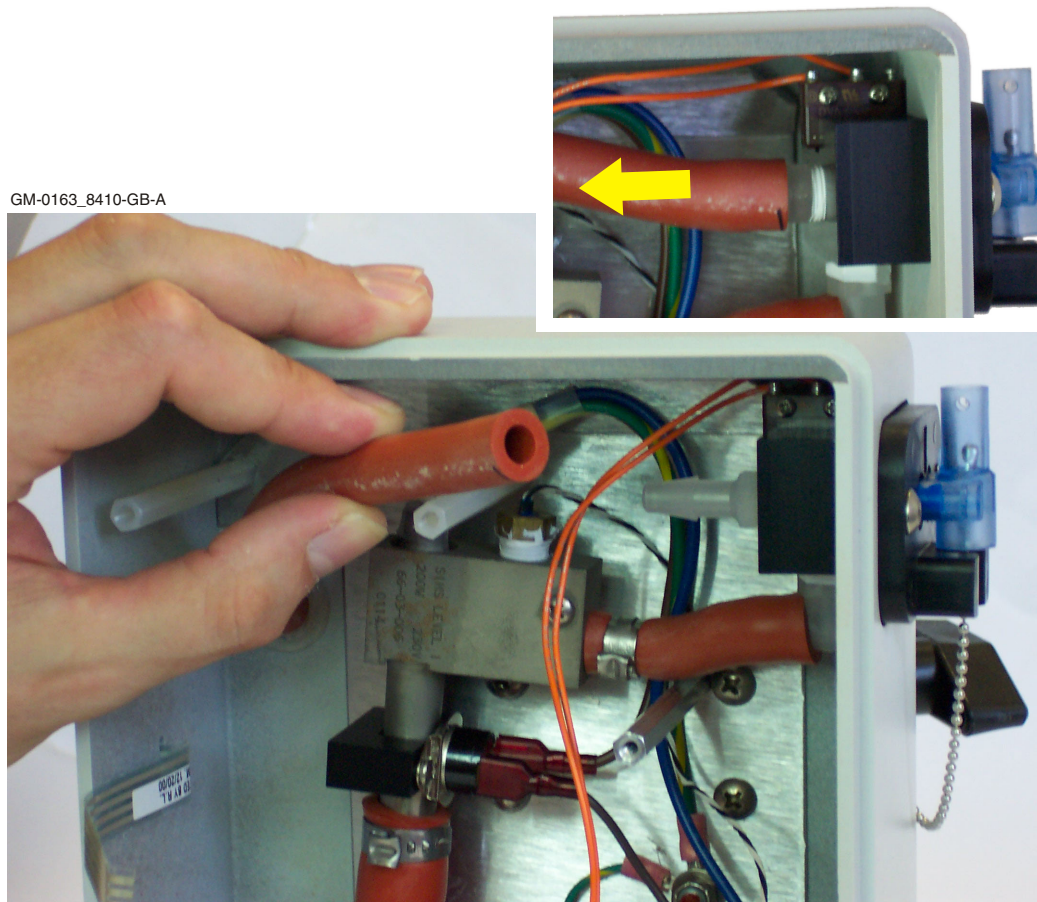

Figure 4 - 11: The Return Pipe

Release it from the interlock block by gentle persuasion. No tools should be needed.

## Step 5: Removing the Chassis

Undo the four poleclamp retaining screws from the rear of the chassis. Be ready to catch the poleclamp if it should fall off the back of the case.

Normally the silicone sealant will prevent this.

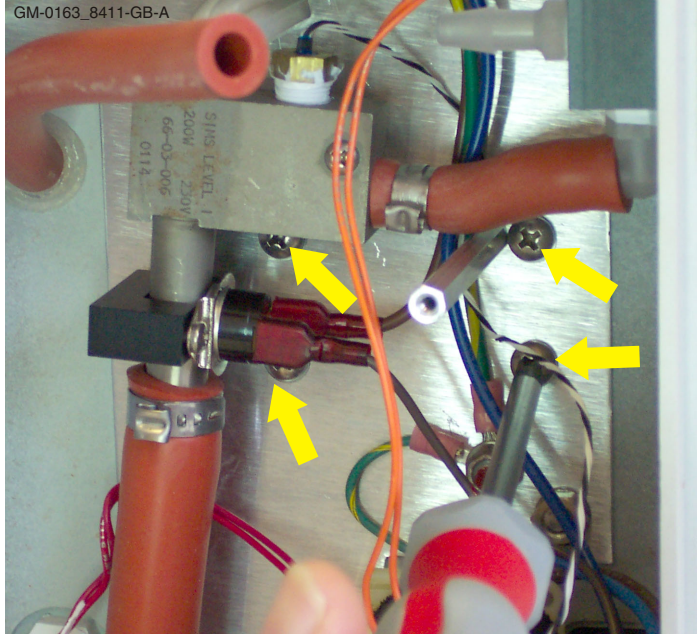
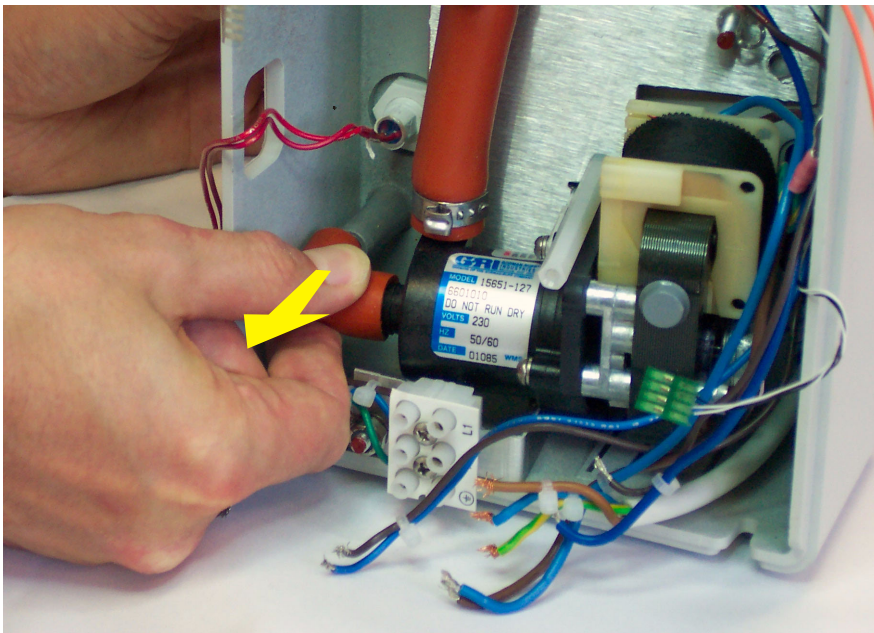

Figure 4 - 12: The Pole Clamp Retaining Screws also hold the Chassis in place



Gently pull on the silicone rubber elbow pump inlet pipe to release it from the spout leading from the reservoir.

Figure 4 - 13: Older Pumps have a rigid moulded plastic elbow here

Slide the chassis forward at the left-hand side until you can release the final silicone tube from the elbow beneath the interlock block. Once that tube is freed, the entire chassis can be taken out.

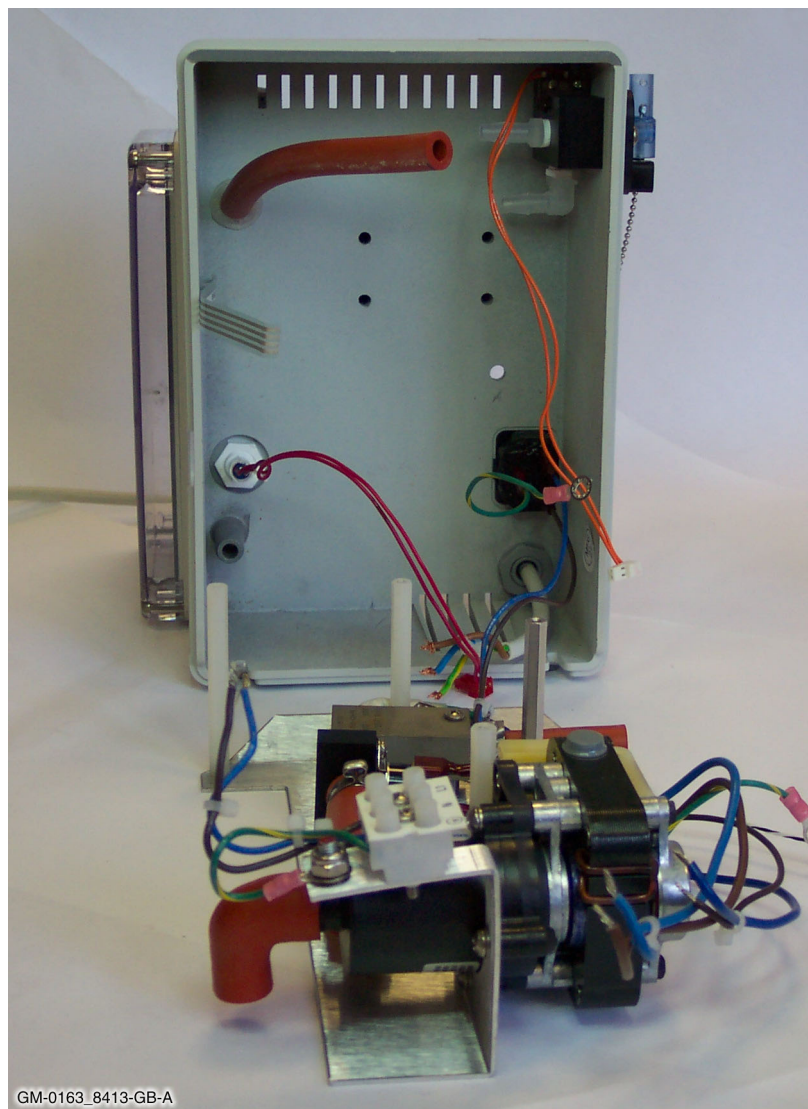

*Figure 4 - 14: Dissection Complete!*



---

## Reassembly

Reassembly is a straightforward process, consisting of following the aforementioned procedures in the reverse order.

### Measurements

While you have the chance on a (presumed) good **HOTLINE®**, make a note of the following resistance measurements. They may be useful when fault finding in future.

- *Pump Motor Coil (Specify March or GRI)*
- *Heater Element*
- *Transformer Primary*
- *Relay K1 Coil*
- *Display Thermistor (J4:1-2) (ambient temp)*
- *Display Thermistor (J4:1-2) (operating temp)*
- *Control Thermistor (J4: 3-4) (ambient temp)*
- *Control Thermistor (J4: 3-4) (operating temp)*

smiths

1

Introduction /  
Specifications

2

Sub-Assemblies

3

Technical Description

4

Disassembly Procedures

5

**Maintenance, Testing  
and Calibration**

6

Troubleshooting

7

Spare Parts

8

Rounding Off

9

Appendix 1 -  
Circuits

10

Appendix 2 -  
PCB Layout

11

Appendix 3 -  
Symbols Glossary

12

Appendix 4 -  
Frequently Asked Questions  
Information Bulletins



**HOTLINE®**

Blood and  
Fluid Warmer

---

# Maintenance

## Before each use

Carefully inspect the HOTLINE® for signs of damage, cracked or split case, insecure poleclamp, damaged mains cable, etc.

If the Disposable Set does not install easily, lubricate the O-Ring Seals.

## Lubricating the O-Ring Seals

Using a cotton swab, apply a small amount of silicone grease (Smiths Medical Part Number EZL 80-04-002) to the O-Rings in the Disposable Set connector block.

If this does not solve the problem, reject the unit.

## After each use

Wipe all external surfaces of the HOTLINE® with a soft cloth, using an aqueous solution of mild detergent. If necessary, the external surfaces may be disinfected using a solution of 10% bleach in distilled water.

- *Do not autoclave.*
- *Do not use alcohol or solvents.*
- *Do not use abrasive cleaning agents.*
- *Do not use cold sterilants.*
- *Do not immerse any part of the HOTLINE® in liquids.*

## Routine Maintenance Tasks

Smiths Medical recommends that preventative maintenance be carried out at specified intervals. Some maintenance tasks need to be repeated at 30-day intervals and others at annual intervals, depending on your choice of recirculating solution.

The three approved recirculating solutions and their associated maintenance protocols are:

Recirculating Solution	At 30-day Intervals	At 12-month Intervals
Sterile Distilled Water	Visual Inspection Lubricate O-Ring Seals Replace Recirculating Solution	Test All Alarms Replace O-Ring Seals Replace Recirculating Solution Verify Temperature Calibration Electrical Safety Test
Isopropyl Alcohol Solution	Visual Inspection Lubricate O-Ring Seals Replace Recirculating Solution	Test All Alarms Replace O-Ring Seals Replace Recirculating Solution Verify Temperature Calibration Electrical Safety Test
Hydrogen Peroxide Solution	Visual Inspection Lubricate O-Ring Seals	Test All Alarms Replace O-Ring Seals Replace Recirculating Solution Verify Temperature Calibration Electrical Safety Test

Precise directions for mixing the above solutions to the correct strength are given on page 54.

Exceptionally, if the unit has had any non-routine servicing or repair work, it will need to undergo a more thorough test and recalibration sequence. This is detailed on page 64 and onwards.

---

## Every 30 days

- Perform a Visual Inspection looking for damage to the case, poleclamp, mains cable, etc.
- Lubricate O-Ring Seals with a cotton swab, applying a small amount of silicone grease to the O-Rings.

### Either, if using **DISTILLED WATER** as the recirculating solution:

- Drain and replace the recirculating solution as described on page 54.

### or, if using **ISOPROPYL ALCOHOL** as the recirculating solution:

- Drain and replace the recirculating solution as described on page 56.

### Finally

- Fill in, sign, and date the maintenance log record!

---

# Every 12 Months

## Alarm Testing

Place the **HOTLINE®** on a suitable firm surface. Visually check that the recirculating solution level in the reservoir is above the MIN mark. Attach a Disposable Set, ensuring that it is free from kinks and twists.

Plug the unit into the electricity supply and switch on. Verify that the unit is working normally (recirculating solution circulating, temperature display gradually rising towards 41°C).

## General Alarm Test



Press the General Alarm Test button. Observe:

- *the GREEN LED extinguishes.*
- *the THREE RED LEDs light up.*
- *the AUDIBLE ALARM commences beeping.*
- *the RECIRCULATING SOLUTION ceases circulating.*

If any of the above responses are missing, the unit must be removed from service and repaired.

## Over Temperature Alarm Test



Allow the unit to run for sufficient time to stabilise the temperature. Press and hold the Over Temperature Alarm Test button. Observe:

- *the DISPLAY rises to 43°C - 44°C .*
- *the GREEN LED extinguishes.*
- *the RED Over Temperature LED lights up.*
- *the AUDIBLE ALARM commences beeping.*
- *the RECIRCULATING SOLUTION ceases circulating.*

If any of the above responses are missing, the unit must be removed from service and repaired.

## Recirculating Solution Level Alarm

Remove the Fill Port plug. Using a non-magnetic tool, gently depress the float switch arm.



*Figure 5 - 1: Depressing the float switch. Here you see an offcut of scrap Disposable Set performing excellently as a non-magnetic probe.*

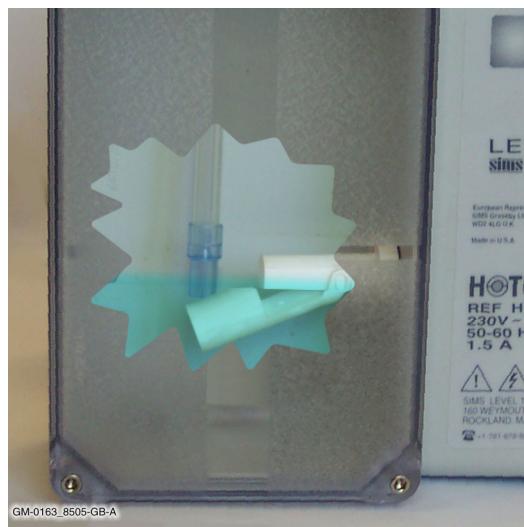

---

Observe that:

- *the GREEN LED extinguishes.*
- *the RED recirculating Solution Level LED lights up.*
- *the AUDIBLE ALARM commences beeping.*
- *the RECIRCULATING SOLUTION ceases circulating.*

If any of the above responses are missing, the unit must be removed from service and repaired. The unit should return to normal operation upon releasing the float switch.

## Disposable Set Interlock Alarm



While the unit is working normally, gently ease the Disposable Set away from the interlock block. **Be aware that a small amount of recirculating solution may escape during this test.** Before the Disposable Set is fully disconnected, the alarm should operate. Observe that:

- *the GREEN LED extinguishes.*
- *the RED Interlock Alarm LED lights up.*
- *the AUDIBLE ALARM commences beeping.*
- *the recirculating SOLUTION ceases circulating.*

If any of the above responses are missing, the unit must be removed from service and repaired. The unit should return to normal operation upon correctly reattaching the Disposable Set.



## Replace O-Ring Seals

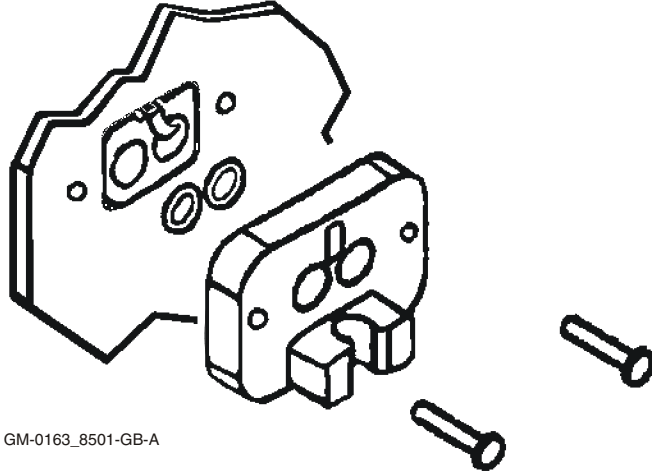

Figure 5 - 2: Getting access to the O-Ring Seals

- Remove the socket head screws with an  $\frac{1}{8}$ -inch Allen key.
- Remove the disposable interface block, being careful of the microswitch lever.
- Using a cotton swab, remove the old O-Rings, and clean out the empty sockets.

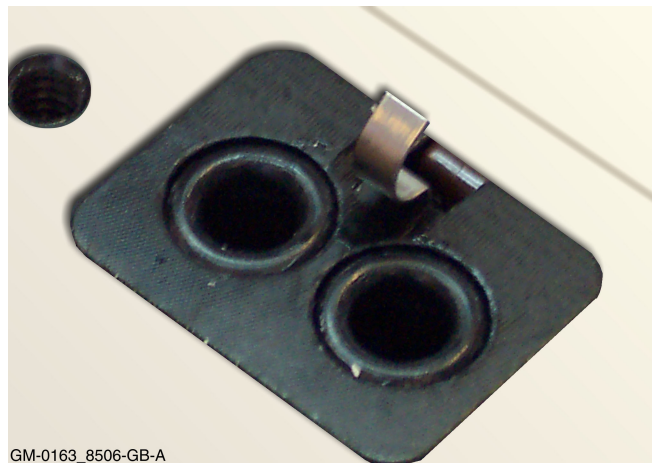

Figure 5 - 3: Revealed: the O-Rings in their niches

- 
- *Apply a smear of silicone grease (Smiths Medical Part Number EZL 80-04-002) to two new O-Rings, and locate them in the sockets.*
  - *Re-attach the disposable interface block.*
  - *Re-fit the socket head screws. Again, take care not to damage or bend the microswitch operating lever.*

*A kit of parts is available to make this task simpler. Please ask for part number reference EZL 80-04-001.*

### **Either, if using DISTILLED WATER as the recirculating solution:**

- Drain and replace the recirculating solution as described on page 54.

### **or, if using ISOPROPYL ALCOHOL as the recirculating solution:**

- Drain and replace the recirculating solution as described on page 56.

### **or, if using HYDROGEN PEROXIDE as the recirculating solution:**

- Drain and replace the recirculating solution as described on page 57.

### **Finally**

- Fill in, sign, and date the maintenance log record!

## Maintenance Solutions

At service intervals of either 12-months or 30-days, depending on the composition of your recirculating solution, you will need supplies of ready mixed solutions to perform maintenance. To make up a batch (1.4 litres) of solution, you will need:

### Formula 1

**140ml of 3% Hydrogen Peroxide PLUS 1260ml distilled water**

This may be used as a disinfectant fluid for flushing the recirculating solution path during routine maintenance, or as a long-life recirculating solution enabling fluid change intervals to be extended to 12-monthly.

### Formula 2

**700ml of 70% Isopropyl Alcohol PLUS 700ml distilled water**

This may be used as a disinfectant fluid for flushing the recirculating solution path during routine maintenance, or as a recirculating solution. It is NOT suitable for long-term use, and must be replaced at 30-day intervals.

## Changing Recirculating Solution (Distilled Water)

If using plain distilled water as the recirculating fluid, then this must be changed at the 30-day service interval, using the procedure given here. Smiths Medical currently recommends using the Hydrogen Peroxide based recirculating solution which allows a 12-monthly recirculating solution change protocol, resulting in a significant reduction of service time.

- *Unplug the HOTLINE®.*
- *(Old case) Remove the Fill Port plug and hold the Unit over a sink to empty the water.*  
*(New case) Deploy the drain tube to empty the Unit.*

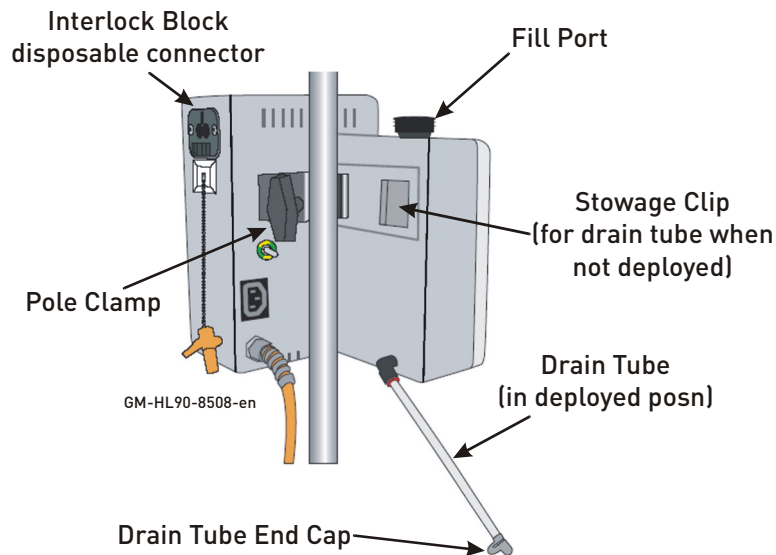

Figure 5 - 4: Rear view of new-style HOTLINE case, showing drain tube

- *Rinse reservoir with distilled water twice.*
- *Refill the reservoir with 1.4 litres of disinfectant flushing solution made to one of the formulae shown in the blue panel above. Do not fill the HOTLINE® reservoir with a Disposable Set in place, as this may result in an airlock in the HOTLINE® warmer.*
- *Connect a Disposable Set to the HOTLINE®.*
- *Plug the Unit in and switch on.*
- *Allow the disinfectant solution to circulate for 30 minutes.*

- 
- *Switch off and disconnect the Unit.*
  - *Empty the unit once more.*
  - *Rinse reservoir with distilled water again.*
  - *Refill the unit with 1.4 litres of sterile distilled water.*
  - *Replace the Fill Port plug.*

**NOTE:** *Unless using one of the approved maintenance solutions, use only sterile distilled or de-ionised water. Failure to do so may lead to a build-up of mineral deposits in the recirculating solution path which may impair heater performance.*

## Changing Recirculating Solution (Isopropyl Alcohol)

Since the Isopropyl Alcohol solution gradually loses potency, it must be replaced at the 30-day service interval using the following procedure:

- *Prepare two batches of 1.4 litres of recirculating solution according to formula 2 above for 35% Isopropyl Alcohol maintenance solution.*
- *Drain the HOTLINE®, and refill with one of the prepared batches.*
- *Install an L-70 or L-70 NI Disposable Administration Set in the HOTLINE®'s Disposable Set connector.*
- *Turn on the HOTLINE® and allow the fresh fluid to circulate for 30 minutes.*

- 
- *Switch off the HOTLINE® and dispose of the Disposable Set in accordance with the usual procedures for your establishment. Drain the Fluid from the HOTLINE® and discard.*
  - *Refill the HOTLINE® with the second of the Isopropyl Alcohol solution batches you made earlier.*

**NOTE:** *If the HOTLINE® requires topping up at any time before the next routine recirculating solution change, make sure you always use the correct mix of Isopropyl Alcohol and Distilled water.*

## Changing Recirculating Solution (Hydrogen Peroxide)

At the annual routine service interval the Hydrogen Peroxide solution must be replaced as follows:

- *Prepare two batches of 1.4 litres of recirculating solution according to formula 1 above for 0.3% Hydrogen Peroxide maintenance solution.*
- *Drain the HOTLINE®, and refill with one of the prepared batches.*
- *Install an L-70 or L-70 NI Disposable Administration Set in the HOTLINE®'s Disposable Set connector.*
- *Turn on the HOTLINE® and allow the fresh fluid to circulate for 30 minutes.*
- *Switch off the HOTLINE® and dispose of the Disposable Set in accordance with the usual procedures for your*

establishment. Drain the fluid from the **HOTLINE®** and discard.

- Refill the **HOTLINE®** with the second of the recirculating solution batches you made earlier.

**NOTE:** If the **HOTLINE®** requires topping up at any time before the next routine recirculating solution change, make sure you always use the correct mix of Hydrogen Peroxide and Distilled water.

## Temperature Checking

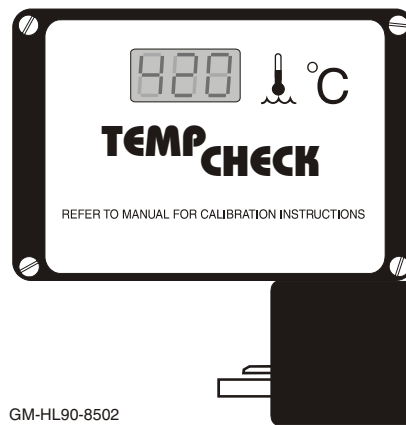

Figure 5 - 5: A **HOTLINE®** HLTA-40 TEMP CHECK wet thermometer

To accurately verify the displayed recirculating solution temperature, you will need a **HOTLINE®** HLTA-40 TEMP CHECK thermometer. This bespoke unit is inserted into the recirculating solution flow and reads the temperature directly from the recirculating solution as it leaves the heater element and internal thermistor sensors. This is the point at which the recirculating solution is at its highest temperature.

Measuring the temperature in the recirculating solution reservoir is less accurate. Typically the temperature here may be several degrees cooler, dependent on ambient temperature and other factors.

---

If you do not have a HOTLINE® TEMP CHECK thermometer, units may be returned to Smiths Medical for temperature verification.

Set up the HOTLINE® ready for use as before. Attach the TEMP CHECK thermometer to the interlock block of the HOTLINE® and connect the Disposable Set to the TEMP CHECK.

Carefully unpeel the black sticker from the back of the HOTLINE®, and loosely attach it in a safe place ready for re-use. Plug the TEMP CHECK's Mains cable into the Auxiliary Outlet socket of the HOTLINE®.

**NOTE:** *The Auxiliary Outlet is for use only with approved accessories supplied by your Smiths Medical distributor for that purpose.*

Run the HOTLINE® for 15 minutes to allow the temperature to stabilise. Verify that:

- the TEMP CHECK indicates a recirculating solution temperature between 41°C and 42°C
- The HOTLINE®'s display indicates the same temperature.

If either of these conditions is not met, the unit will require either recalibration or repairing and recalibration before it can be returned to active service.

If both conditions are satisfied, dismantle the test assembly, and replace the black sticker over the Aux socket. Document the date and results of your tests and return the HOTLINE® to active service.



---

## Routine Maintenance Checklists

You may freely photocopy the checklists on the next three pages to act as a continuing record of your routine HOTLINE® HL-90 maintenance.

The correct checklist to use is dependent on the choice of protocol used for maintenance on the HOTLINE®s in your care. If you choose to stick to the traditional distilled water recirculating solution, you will need the first checklist. This allows for the changing of the recirculating solution on a monthly cycle.

Otherwise, the third checklist corresponds with Smiths Medical's recommended protocol of having a 12-month interval between solution changes, and using a disinfectant mixture as the recirculating solution on a permanent basis.

In some territories, Hydrogen Peroxide may not be readily available, or it may be that it is not included in the establishment's preferred protocols. If that is the case, and it is still necessary to maintain a disinfectant recirculating solution, then the second checklist gives the correct pattern when using Isopropyl Alcohol solution with a 30-day replacement cycle. It is not permitted to use the Isopropyl Alcohol solution on a 12-monthly replacement cycle as it loses its potency much more rapidly than the recommended Hydrogen Peroxide solution. For this reason, batches of Isopropyl Alcohol solution (Formula 2) should ideally be freshly mixed immediately before use.



# Recirculating Solution is 35% Isopropyl Alcohol

Unit Serial Number	
Date of Acquisition	
Month 1 was when?	

	MONTH 1	MONTH 2	MONTH 3	MONTH 4	MONTH 5	MONTH 6	MONTH 7	MONTH 8	MONTH 9	MONTH 10	MONTH 11	MONTH 12
Change Recirculating Solution	✓	✓	✓	✓	✓	✓	✓	✓	✓	✓	✓	✓
Grease O-Ring Seals	✓	✓	✓	✓	✓	✓	✓	✓	✓	✓	✗	✓
Replace O-Ring Seals	✗	✗	✗	✗	✗	✗	✗	✗	✗	✗	✗	✗
General Alarm Test	✗	✗	✗	✗	✗	✗	✗	✗	✗	✗	✗	✗
Over Temperature Test	✗	✗	✗	✗	✗	✗	✗	✗	✗	✗	✗	✗
Interlock Alarm Test	✗	✗	✗	✗	✗	✗	✗	✗	✗	✗	✗	✗
Low Recirculating Solution Alarm Test	✗	✗	✗	✗	✗	✗	✗	✗	✗	✗	✗	✗
Verify Temperature Calibration	✗	✗	✗	✗	✗	✗	✗	✗	✗	✗	✗	✗

GM-01.63\_8509-GB-A

START  
A FRESH  
RECORD CARD  
FOR THIS  
HOTLINE®  
NOW



*Tested by*

*Date of Test*

# Recirculating Solution is 0.3% Hydrogen Peroxide

Unit Serial Number	
Date of Acquisition	
Month 1 was when?	

	MONTH 1	MONTH 2	MONTH 3	MONTH 4	MONTH 5	MONTH 6	MONTH 7	MONTH 8	MONTH 9	MONTH 10	MONTH 11	MONTH 12
Grease O-Ring Seals	✓	✓	✓	✓	✓	✓	✓	✓	✓	✓	✓	✗
Replace O-Ring Seals	✗	✗	✗	✗	✗	✗	✗	✗	✗	✗	✗	✓
Change Recirculating Solution	✗	✗	✗	✗	✗	✗	✗	✗	✗	✗	✗	✓
General Alarm Test	✗	✗	✗	✗	✗	✗	✗	✗	✗	✗	✗	✓
Over Temperature Test	✗	✗	✗	✗	✗	✗	✗	✗	✗	✗	✗	✓
Interlock Alarm Test	✗	✗	✗	✗	✗	✗	✗	✗	✗	✗	✗	✓
Low Recirculating Solution Alarm Test	✗	✗	✗	✗	✗	✗	✗	✗	✗	✗	✗	✓
Verify Temperature Calibration	✗	✗	✗	✗	✗	✗	✗	✗	✗	✗	✗	✓

START  
A FRESH  
RECORD CARD  
FOR THIS  
HOTLINE®  
NOW



*Tested by*

*Date of Test*

GM-01.63\_8507-GB-A

# Full Service Test Procedure

This sequence must be used:

- either after any repair or service work where the case was opened,
- or when the unit has failed temperature calibration verification.

## Things you will need

- Room Thermometer
- TEMP CHECK HLTA-40
- HOTLINE® Disposable Set L-70
- Small and Medium Straight Screwdrivers
- Non-magnetic Probe

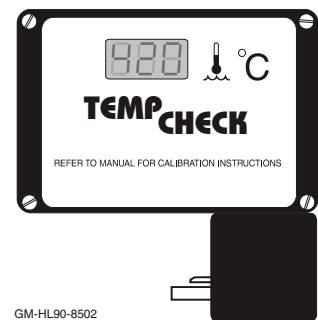

**CAUTION:** Take care while operating the HOTLINE® with the case front open. Mains voltages are present inside. Avoid contact with any internal components not specified in this procedure.

**CAUTION:** The Auxiliary Outlet is for use only with approved accessories supplied by your Smiths Medical distributor for that purpose.

**CAUTION:** Do not fill the HOTLINE® reservoir with a Disposable Set in place. Failure to remove the Disposable Set before the fill procedure may result in an airlock in the HOTLINE® warmer.

**NOTE:** When filling the HOTLINE®, use approved recirculating solutions only. Failure to do so may cause damage to the equipment.

**NOTE:** Check the calibration due date on the back of the TEMP CHECK before commencing this procedure.

**NOTE:** TEMP CHECK thermometers are designed for measuring circulating recirculating solution flow only and are not intended for measuring ambient (air) temperatures.

---

# HL-90 Service Test Specification

## Setup

- [i] Fill unit up with de-ionised water, attach an L-70 Disposable Set, turn on and let the HOTLINE® run for 40 minutes minimum.*
- [ii] Check that the Ambient Room Temperature is  $22.0^{\circ}\text{C} \pm 2.0^{\circ}\text{C}$ . If the temperature is out of this specified range, do NOT proceed with this calibration procedure.*
- [iii] Remove the Disposable Set, install the Temp Check to the unit, and re-attach the Disposable Set.*
- [iv] Remove case front. Confirm that J201 is in the "40" position. (See Appendix 2)*

## Check For Leaks

- [i] Observe that the fluid is circulating in the HOTLINE® reservoir.*
- [ii] Check all fittings and seams in the recirculating system for leaks.*

## Interlock Switch Test

- [i] Slowly release the Temp Check from the interlock switch. A small amount of recirculating fluid may escape. The alarm should activate.*
- [ii] Return the Temp Check to the interlock switch. Unit should return to being operational.*

## Alarm Test Switch

- [i] Depress the General Alarm Test switch.
- [ii] The "Operational" or "Warming" LED should turn off. All "Alarm" LED's should be flashing and the alarm must be audible.
- [iii] Release switch and the system should become operational again.

## Check Float Switch

- [i] To check float switch, remove the fill port cap and depress the float switch (which is located inside the reservoir) with a non-magnetic float switch probe.
- [ii] The "Recirculating Solution Level" warning LED should light and the alarm will be audible. The Green "Operational" LED and the pump should turn off.
- [iii] Release the float switch and the system will once more become operational.

## Set Recirculating Solution Temperature

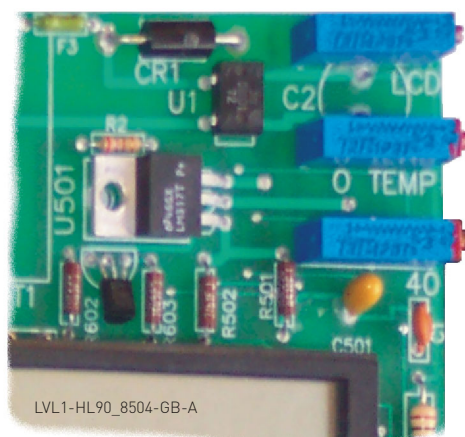

- LCD** Used to align the displayed temperature with the actual water temperature
- O TEMP** Adjusts the set point for the Over Temperature Alarm
- H20** Sets the operating point of the temperature control circuit. On older pumps this may be labelled "40" as shown here.

Figure 5 - 6: Purpose of the Pots

- 
- [i] *If necessary, turn the "H2O" or "40" temperature set point adjustment pot clockwise to increase recirculating solution temperature, or counter-clockwise to decrease recirculating solution temperature. A quarter turn of the pot corresponds to a change in temperature of about 0.3°C. Allow 5 minutes between adjustments for the temperature to stabilise .*
  - [ii] *Set unit to run at 41.9°C ± 0.1°C as measured by the TEMP CHECK and allow to stabilise.*

### Set Over Temperature Alarm Set Point

- [i] *Adjust the "LCD" adjustment pot so the LCD reads 43.1°C. If the alarm activates before the display reaches 43.1, then adjust the over temperature pot clockwise until the alarm turns off and continue adjusting LCD.*
- [ii] *Adjust the over temperature pot counter-clockwise until the alarm sounds.*
- [iii] *Adjust the "LCD" adjustment pot counter-clockwise and confirm that the alarm deactivates.*
- [iv] *Adjust the "LCD" adjustment pot clockwise again and confirm that the alarm activates at 43.1°C.*
- [v] *Repeat the test twice to confirm the activation set point.*

### Calibrate LCD

- [i] *Turn the "LCD" adjustment pot on the PCB so that the unit display (LCD) is equal to the that of the Temp Check ± 0.0°C.*
- [ii] *To confirm the Over Temperature Alarm, depress and hold the over temperature switch on the side of the enclosure.*



- 
- [iii] The PCB display should increase to  $43.6^{\circ}\text{C} \pm 0.3^{\circ}\text{C}$  and then the Over Temperature Alarm should activate. Release and the unit should return to normal operation.*
  - [iv] Attach and close the case front.*

### Idle Check

- [i] Allow the unit to run at  $41.9^{\circ}\text{C} \pm 0.1^{\circ}\text{C}$  for 15 minutes and confirm that the display is stable for a further 5 minutes.*
- [ii] Record the ambient room temperature which should be  $22.0^{\circ}\text{C} \pm 2.0^{\circ}\text{C}$ . If it is out of this range you can not complete this calibration. You must start a fresh calibration sequence.*

### Safety Test

- [i] Safety test the HOTLINE<sup>®</sup> in accordance with the Electrical Safety Testing System normally used by your establishment.*

### Test Completion

- [i] Drain the distilled water and refill unit with 1.4 litres of either fresh sterile distilled water or whatever formula is the usual establishment practice.*
- [ii] Verify that the Service History record has been completed. Clean case and return to service.*

---

## Other Territories

Nominal Temperature	Water Temperature (paragraph 6)	Over Temperature Set Point (paragraph 7)
40	39.9	41.1
42	41.9	43.1

It is common practice both in the U.S.A. and in the U.K. to set a nominal temperature of 42°C.

In other territories, a different set point (40°C) may be adopted as the “normal” setting.

For reference, the details for the alternative Nominal Temperature adjustment set points are shown here.

smiths

1

Introduction /  
Specifications

2

Sub-Assemblies

3

Technical Description

4

Disassembly Procedures

5

Maintenance, Testing  
and Calibration

6

Troubleshooting

7

Spare Parts

8

Rounding Off

9

Appendix 1 -  
Circuits

10

Appendix 2 -  
PCB Layout

11

Appendix 3 -  
Symbols Glossary

12

Appendix 4 -  
Frequently Asked Questions  
Information Bulletins



**HOTLINE®**

Blood and  
Fluid Warmer

## Troubleshooting Hints

The following troubleshooting hints are organised into two groups - those involving alarm conditions and those that refer to conditions that do not normally incur an alarm.

### Alarm State Hints

#### Over Temperature Alarm ON continuously

Problem	Possible Causes	Remedial Action
Insufficient recirculating solution flow.	Warming Set kinked: free flow is not possible.	Visually check, and if necessary straighten.
	Airlock in Fluid Warming Set.	Visually check for bubbles in Fluid Warming Set: if present, disconnect set, manipulate to release bubbles, reconnect. If no bubbles visible, disconnect set, gently swirl HOTLINE® around to dislodge any trapped air in the fluid path, and try again. In extreme cases it may be necessary to empty and refill the HOTLINE® to eliminate the air. Avoid potential airlocks by only filling HOTLINE® with the Fluid Warming Set DISCONNECTED.
	Pump Seized.	Replace, using GRI pump replacement kit 45-330-13.
Electrical or Electronic Failures.	Triac Short circuit.	Test and Replace.
	Opto Defective.	Test and Replace.
	Thermistor defective.	Verify by substitution or Ohmmeter tests.
Other.	Over Temperature alarm set point too low.	Recalibrate using TEMP CHECK.
	Unit accidentally filled with hot recirculating solution.	Wait until it cools, or refill with fresh cold recirculating solution.
	Ambient temperature too high.	Room temperatures above 42°C will cause the alarm to trigger.

### Over Temperature Alarm not working

Problem	Possible Causes	Remedial Action
Display reading correctly.	Over Temperature Alarm set point too high.	Recalibrate using TEMP CHECK.
Display not reading correctly.	Thermistor defective.	Test and replace. Recalibrate.

### Fluid Warming Set Interlock Alarm ON continuously

Problem	Possible Causes	Remedial Action
Microswitch not being made.	Fluid Warming Set not fitted correctly.	Push firmly home.
	Microswitch lever out of shape.	If not made when set is correctly installed, replace Switch.
Microswitch is being made.	Faulty Microswitch.	Replace Switch.
	Wiring or PCB fault.	Check J3 for loose connection.

### Fluid Warming Set Interlock Alarm not working

Problem	Possible Causes	Remedial Action
Switch not being operated.	Microswitch lever stuck.	Replace Switch.
Switch is being operated.	Defective Microswitch	Replace Switch.
	Wiring or PCB fault.	Rectify.

### Recirculating Solution Level Alarm ON continuously

Problem	Possible Causes	Remedial Action
Recirculating Solution is Low.	Recirculating Solution really is low	Add Recirculating Solution!
Recirculating Solution is OK.	Sticky Float Switch.	Replace Switch.
	Wiring or PCB fault.	Rectify.

### Recirculating Solution Level Alarm not working

Problem	Possible Causes	Remedial Action
Recirculating Solution is low.	Defective Float Switch.	Replace Float Switch.
	Wiring or PCB fault.	Check J2 for loose connection.

## Non-Alarm related Faults

Problem	Possible Causes	Remedial Action
No Power.	Is the Unit plugged into a good socket and turned ON?	Test socket with some other Mains powered device.
	Fuses F1 or F2 blown?	Check with Ohmmeter.
	Transformer open circuit, or F3 blown?	If there is no DC power on the board, no Mains power will be supplied to the heater or pump, and all indicators will be off.
Unit will not heat up.	Bad T-Stat, Triac or Heater.	Identify and eliminate: replace faulty components.
	Idle Temperature set point too low.	Recalibrate.
	Ambient Temperature too high.	This has been known in field hospitals in the Gulf.
Floating or erratic LCD reading.	Bad LCD Unit.	Test by substitution.
	Bad 5v Regulator.	Test and Replace.
Warming Set hard to install.	Dry O-Rings.	Re-grease O-Rings.
Recirculating Solution leaks at Warming Set connector.	Worn O-Rings.	Replace O-Rings.

smiths

1

Introduction /  
Specifications

2

Sub-Assemblies

3

Technical Description

4

Disassembly Procedures

5

Maintenance, Testing  
and Calibration

6

Troubleshooting

7

Spare Parts

8

Rounding Off

9

Appendix 1 -  
Circuits

10

Appendix 2 -  
PCB Layout

11

Appendix 3 -  
Symbols Glossary

12

Appendix 4 -  
Frequently Asked Questions  
Information Bulletins



**HOTLINE®**

Blood and  
Fluid Warmer



# Hotline® Spare Parts List

For HL-90 with original style two-part case			
1	1	HL-90 Enclosure	64-02-005
2	1	HL-90 Front Cover	64-02-025
3	1	HL-90 Tank	64-02-006
4	1	HL-90 Tank Cover	64-02-024
5	1	Fillport Cover HOTLINE®	64-10-025
6	1	Washer for 64-10-025	64-10-028
7	1	Fillport Bead Chain	62-05-023
8	1	End Connector, Bead Chain	62-05-024

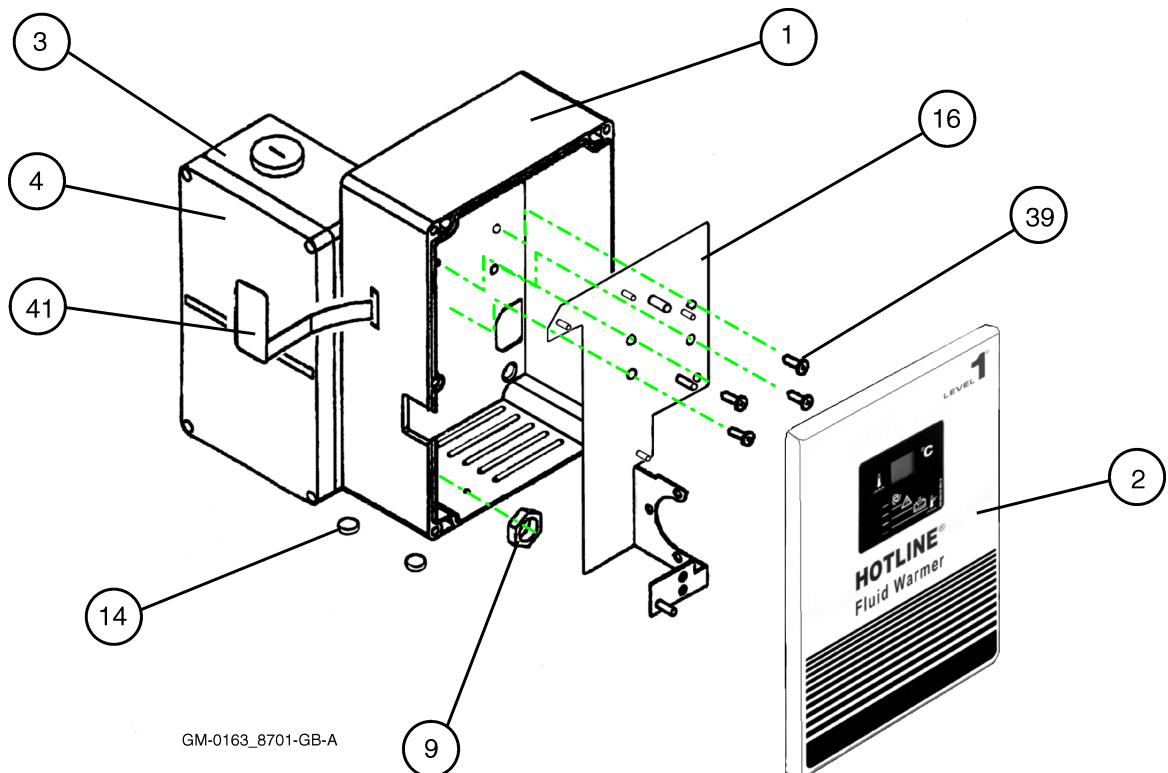

For HL-90 with single-part (1.5) case			
1	1	HL-90 1.5 Enclosure (badged for 115v) HL-90 1.5 Enclosure (badged for 230v)	78-03-090 78-03-095
2	1	HL-90 1.5 Front Cover	64-02-052
4	1	HL-90 1.5 Reservoir Cover	64-02-050
-	1	HL-90 1.5 Reservoir Cover Gasket	62-40-036
5	1	Fillport Cap (with moulded retainer)	62-31-013

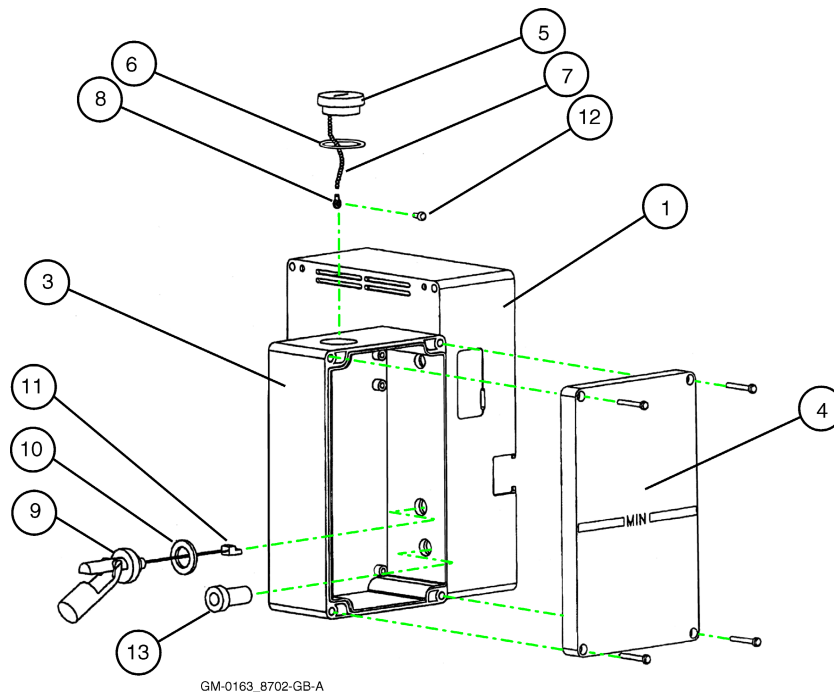

Float Switch Parts			
9	1	Float Switch	60-40-026
10	1	Float Switch Sealing Washer	62-40-011
11	1	AMP Connector 3-way	60-40-006
12	1	Bolt M3x6mm PAN Head	62-01-036
13	1	Inlet Tube	62-07-021
14	6	Feet	62-40-012

Internal Recirculating Solution Path Parts			
15	1	1/4 inch OD Silicone Tube	62-20-013
16	1	HL-90 Chassis	64-01-032
17	1	200W Heater ( 115V )	66-03-005
18	1	200W Heater ( 230V )	66-03-006
19	1	Red Ring Lug	60-47-025
20	1	Red Shield Lug	60-47-032
21	1	T-Stat 3455R-350-574-0	60-25-002
22	1	T-Stat bracket	64-01-052
23	2	Bolt 6-32 x 3/8 inch	62-01-008
24	1	Clamp 1/2 inch	62-05-028
25	1	1/4 inch OD Silicone Tube	62-20-013
26	1	1/2 inch OD Silicone Tube	62-20-014
27	2	Clamp 13/16 inch 21.0-706R	62-05-025
28	1	Thermistor Dual	60-06-003
29	1	Bolt 6-32 x 7/8 inch	62-01-032
30	1	AMP Connector 4-way	60-46-029

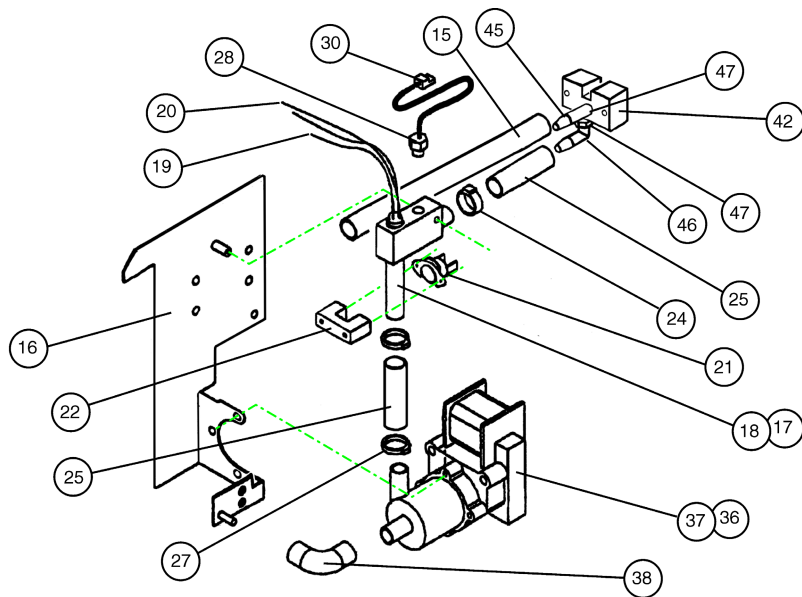

GM-0163\_8700-GB-A

PCB and Mounting Parts			
Item	Qty	Description	Part Number
31	1	Assembled PC Board (US)	60-60-090
32	1	Assembled PC Board (Int)	70-02-096
33	4	Bolt 6-32 x 3/8 inch	62-01-008
34	1	Standoff 6-32 x 2 3/4 inch Aluminium	62-05-020
35	3	Standoff 6-32 x 2 3/4 inch Nylon	62-05-021

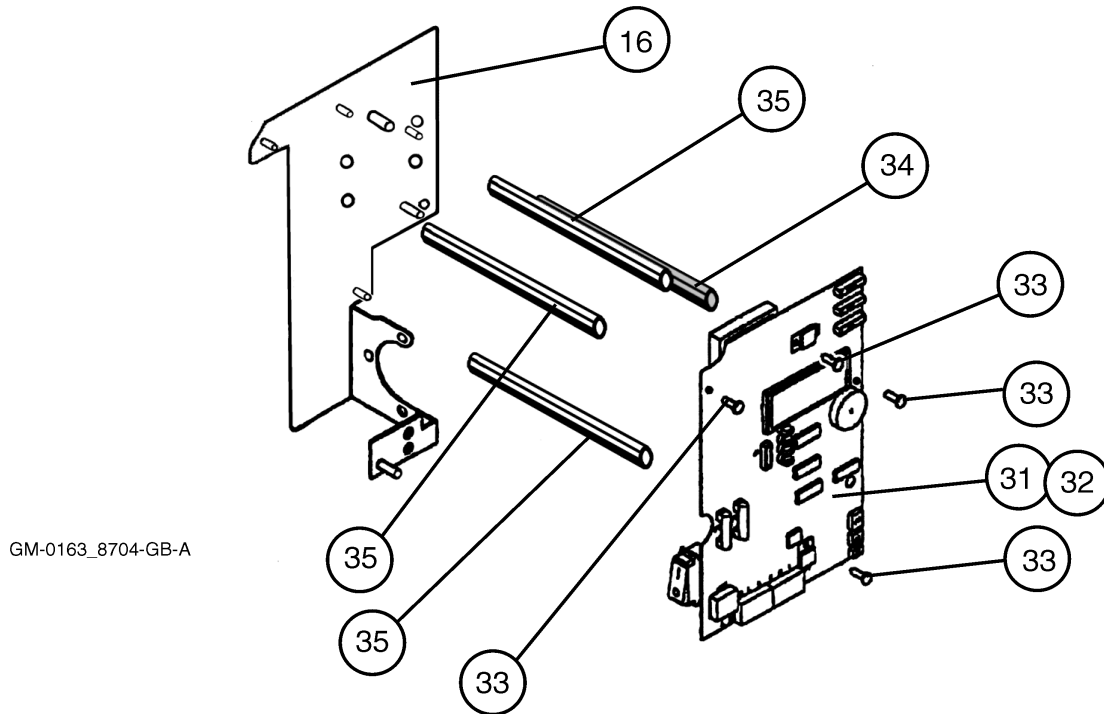

Water Pump and other Parts			
Item	Qty	Description	Part Number
36	1	GRI Pump and Motor 115V AC	66-01-008
37	1	GRI Pump and Motor 230V AC	66-01-010
39	4	Poleclamp Screws 10-24 x 1/2 inch	62-01-005
40	1	Earth Stud Nut M6	62-02-013
41	1	Membrane Switch (NEK)	60-40-027

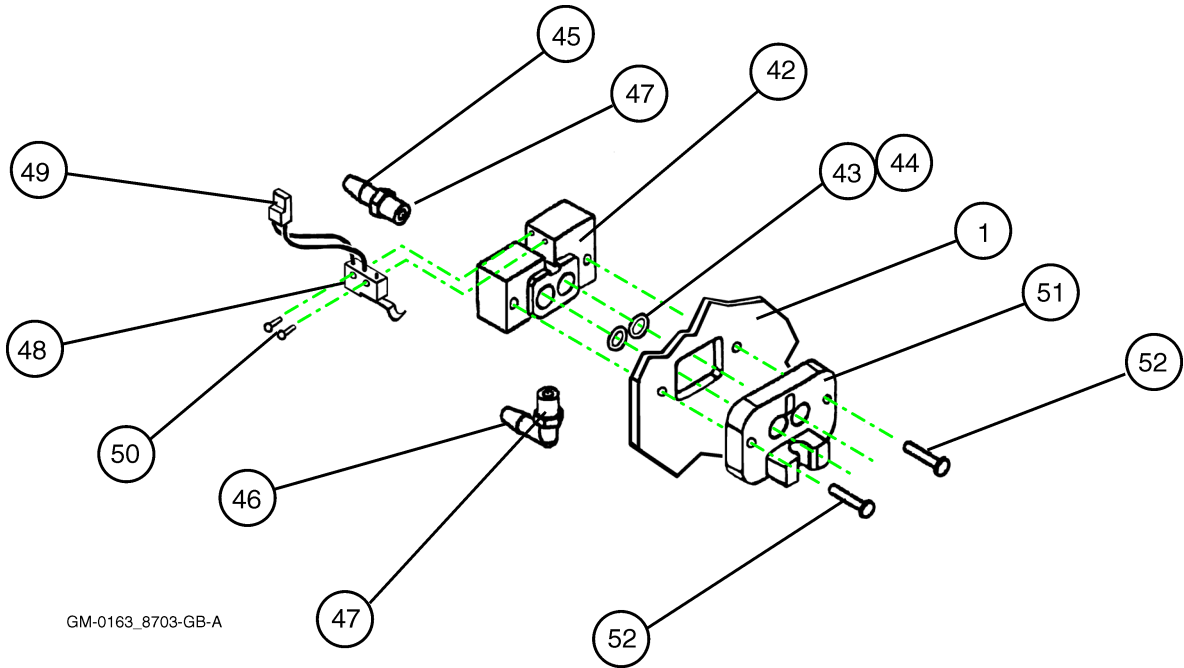

### Disposable Attachment and Interlock Parts

42	1	Interlock Block	64-10-021
43	2	O-Ring Seal AS-568-108	62-40-010
44	-	O-Ring Lube	80-04-002
45	1	Straight Fitting 1/8 NPT 1/4 Barb	62-22-026
46	1	Elbow Fitting 1/8 NPT 1/4 Barb	62-22-027
47	-	PTFE Thread Tape	62-35-004
48	1	Microswitch Round 311	60-40-029
49	1	AMP Connector 2-way	60-46-005
50	2	Bolt 2-56 x 1/2 inch	62-10-030
51	1	Plate Clip	72-06-026
52	2	Bolt 10-32 x 3/4 inch	62-01-037



Pole Mounting Parts				
67	1	T-Bar Knob		64-10-027
68	1	Swivel Screw		62-05-022
69	1	Swivel Screw Foot		62-31-008
70	1	Poleclamp Block		64-10-026
71	-	Clear Silicone		

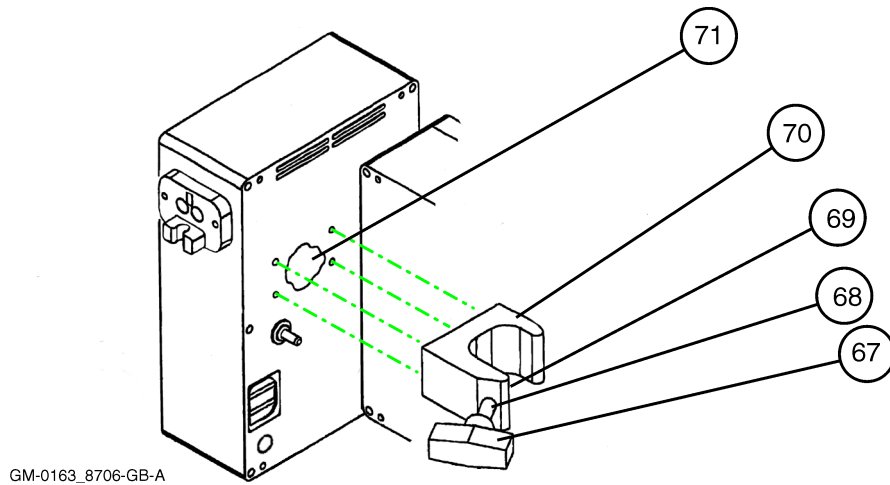

smiths

1

Introduction /  
Specifications

2

Sub-Assemblies

3

Technical Description

4

Disassembly Procedures

5

Maintenance, Testing  
and Calibration

6

Troubleshooting

7

Spare Parts

8

Rounding Off

9

Appendix 1 -  
Circuits

10

Appendix 2 -  
PCB Layout

11

Appendix 3 -  
Symbols Glossary

12

Appendix 4 -  
Frequently Asked Questions  
Information Bulletins



**HOTLINE<sup>®</sup>**

Blood and  
Fluid Warmer



---

## Rounding Off

This section collects together various loose ends, and in no particular order attempts to knit them together. Firstly, there's the update history and modification status for the HOTLINE®.

### Updates

#### New Case

Since 2001, the HOTLINE® has been cased in the "1.5" style unitary construction combination enclosure and recirculating solution reservoir. Earlier models had a separate recirculating solution reservoir bonded onto the rear. The 1.5 style casing covers and gaskets are not interchangeable with the original case.

There is no reason to automatically retire an old style case at routine service, unless it has been damaged, or it is desired to perform cosmetic upgrading.

### Modifications

#### Two-Second Delay

Current production units, for some time now, have had a two-second delay circuit in the Over Temperature Alarm circuit. This has almost no effect on alarms triggered by a change in temperature, since temperature changes tend to be relatively slow events. However, if the alarm is being triggered by operation of the "Test" button, the original instantaneous action could be too sensitive for comfort.

This conversion can be applied retrospectively to older HL-90 units.

Replace R107 with a 34K ¼W component, R108 with a 10M ¼W component and C101 with a 47 µF component rated at 12V or greater . The new component for C101 will probably need to be placed on the rear of the PCB. Its “+” terminal is the connection furthest away from the LCD. Use a plastic spacer to support the capacitor, and prevent shorting to the PCB tracks.

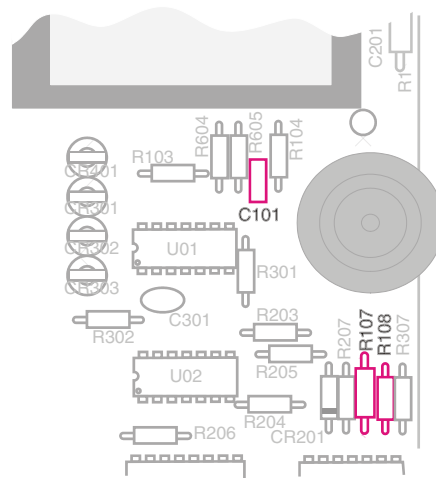

Figure 8 - 1: Location of components for two-second delay update

This modification is not a safety related issue, so its implementation is not mandatory. It is, however, recommended, and HOTLINE® fluid warmers returned to Smiths Medical for service will be routinely updated with this modification.

---

## GRI Pump

The original HOTLINE® units were manufactured with pumps made by March. This pump became unavailable in 1998 and an alternative pump, made by GRI was substituted.

Mechanical differences between the two pump types meant that a number of consequential changes to the mechanical assembly were also needed; the inlet fitting, originally a rigid elbow by SMC, became a flexible silicone rubber part. The fixing holes for the pump / motor in the chassis had to change, so a revised chassis was implemented. Because of these factors, a defective March pump cannot simply be substituted.

A complete chassis fitted with GRI pump and motor is available as an upgrade kit (UK part no EZL 80-040-11). Full instructions for performing the transplant are included with the kit (which incidentally also includes the components for the two-second delay update detailed above).

No safety issues are involved, and no reliability concerns have been raised in connection with the March pump, and so this upgrade is only recommended in case of damage, leakage, or excessive wear to the original pump or motor. If it is not necessary for completing the repair, the March pump does not need to be replaced.

Without dismantling the entire unit, it is not easy to see which pump is fitted. However, if the front case cover is open, and you look behind the Mains input terminals, you can easily see the colour of the water inlet. GRI pumps have the ORANGE silicone rubber elbow; March pumps use a rigid black SMC fitting.

For **HOTLINE®** units equipped with GRI pumps, this inlet pipe will be **ORANGE**.

On March-equipped pumps, the equivalent fitting is black

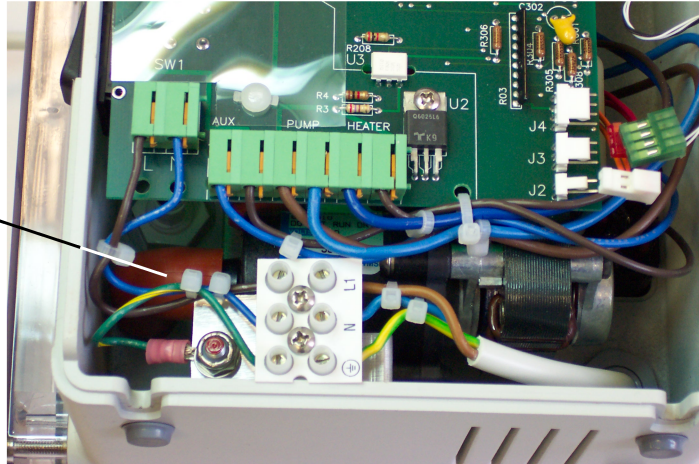

GM-0163\_8802-GB-A

*Figure 8 - 2: Looking for clues!*

## Float Switch Washer

On August 16th 2005, a memorandum was issued detailing an unexpected side effect of changing to the hydrogen peroxide solution for long term use as recirculating solution. The black neoprene foam washer used to seal the float switch body in the reservoir tank was showing signs of breakup, and being adversely affected by the hydrogen peroxide. Over time, the recirculating solution would turn cloudy or discoloured, and eventually the washer would leak and/or disintegrate.

It is recommended that any black foam washer, whether or not it shows signs of degradation, be replaced with the new part made from orange silicone rubber. The part number remains as 62-40-011, and it is available FOC from your local Smiths Medical Distributor on request.

## HOTLINE<sup>®</sup> Quiz

- [1] What is the maximum height above floor level allowed for a HOTLINE<sup>®</sup> on an IV pole?

40 inches

42 inches

44 inches

46 inches

- [2] The HOTLINE<sup>®</sup> is connected to a viable Mains source, but no LEDs are ON, and the pump is not running. Some of these components can be instantly ruled out and others are valid suspects. Put "X"s against those components that you think could **not** possibly be the problem.

Regulator U501

Relay K1

Transformer T1

Triac U2

Control Thermistor

Display Thermistor

- [3] Which of these is the symbol for the Recirculating Solution LOW Level Alarm?



[4] What is the function of the control identified by this symbol?



Switch on Heater

Test All Alarms

Switch on Pump

Clear Airlock

[5] Which of these is *not* required by the 30-day routine maintenance?

General Alarm Test

Over Temperature Alarm Test

Low Water Alarm Test

Re-grease O-Rings

[6] Which of these is an acceptable formula for a solution suitable for long-term use in the system as a recirculating solution?

140 mL 3% Hydrogen Peroxide + 1180 mL Distilled water

140 mL 3% Hydrogen Peroxide + 1260 mL Distilled water

140 mL 3% Hydrogen Peroxide + 1320 mL Distilled water

140 mL 3% Hydrogen Peroxide + 1400 mL Distilled water

---

[7] Aside from Hydrogen Peroxide, which other active ingredient (at a suitable dilution strength) is specified as appropriate for disinfecting the HOTLINE®'s internal components?

Ethyl Alcohol  
Methyl Glycol Alcohol

Isopropyl Alcohol  
Isoil-glycoil Bike-oil

[8] Why is measuring the recirculating solution reservoir temperature with a thermometer not an accurate method for calibrating the HOTLINE®?

Tick as many reasons as you feel are valid.

You can never be 100% sure that all the solution in the tank has passed through the heater at least once.

The tank's solution is only at atmospheric pressure, so its temperature is lower than the higher pressure solution downstream from the pump.

The powerful magnet in the float switch attracts cool-ions and repels hot-ions in the solution, so making the temperature distribution in the tank uneven.

The solution has cooled by the time it returns to the tank and mixed with the bulk of the solution mass.

**Title of Training Program** .....

Trainee (optional) ..... Location .....

Program Presenter ..... Date .....

## General

1) How did you (or your boss) find out about this course?

Magazine advert  Colleague (this establishment)

S.M.I. Ltd Rep  Colleague (another establishment)

Other (what?) .....

2) How well did the course meet your training objectives?

Not at all 

1	2	3	4	5
---	---	---	---	---

 Completely

3) What objectives did it fail to meet?

.....  
.....

4) Would you recommend this course to others in your position? Yes / No

## Course Content

Was the quantity of information in this course sufficient for this topic?

Not enough 

1	2	3	4	5
---	---	---	---	---

 Too much

Was the level of the course content appropriate?

Too basic 

1	2	3	4	5
---	---	---	---	---

 Too advanced

Was the course content relevant to you in your job?

Not at all 

1	2	3	4	5
---	---	---	---	---

 Exactly right

## Course Conditions

What was your opinion of the facilities where this course was held?

Not good 

1	2	3	4	5
---	---	---	---	---

 Very good



# Course Presentation

9) What was your opinion of the instructional materials provided with this course?

(marks for (a) quality ...

Not good 

1	2	3	4	5
---	---	---	---	---

 Very good

... and (b) appropriateness)

Not good 

1	2	3	4	5
---	---	---	---	---

 Very good

10) What was your opinion of the A-V or multimedia aids (if any) used in this course?

(marks for (a) quality ...

Not good 

1	2	3	4	5
---	---	---	---	---

 Very good

... and (b) appropriateness)

Not good 

1	2	3	4	5
---	---	---	---	---

 Very good

11) What was your opinion of the course presenter?

(marks for (a) knowledge ...

Not good 

1	2	3	4	5
---	---	---	---	---

 Very good

... and (b) effectiveness at communicating)

Not good 

1	2	3	4	5
---	---	---	---	---

 Very good

## Feedback, please!

12) What improvements would you suggest for this course?

.....  
.....  
.....

13) What suggestions would you make regarding future courses?

.....  
.....  
.....

**Thank you for taking the time to complete this evaluation!**

smiths

1

Introduction /  
Specifications

2

Sub-Assemblies

3

Technical Description

4

Disassembly Procedures

5

Maintenance, Testing  
and Calibration

6

Troubleshooting

7

Spare Parts

8

Rounding Off

9

Appendix 1 -  
Circuits

10

Appendix 2 -  
PCB Layout

11

Appendix 3 -  
Symbols Glossary

12

Appendix 4 -  
Frequently Asked Questions  
Information Bulletins



**HOTLINE®**

Blood and  
Fluid Warmer

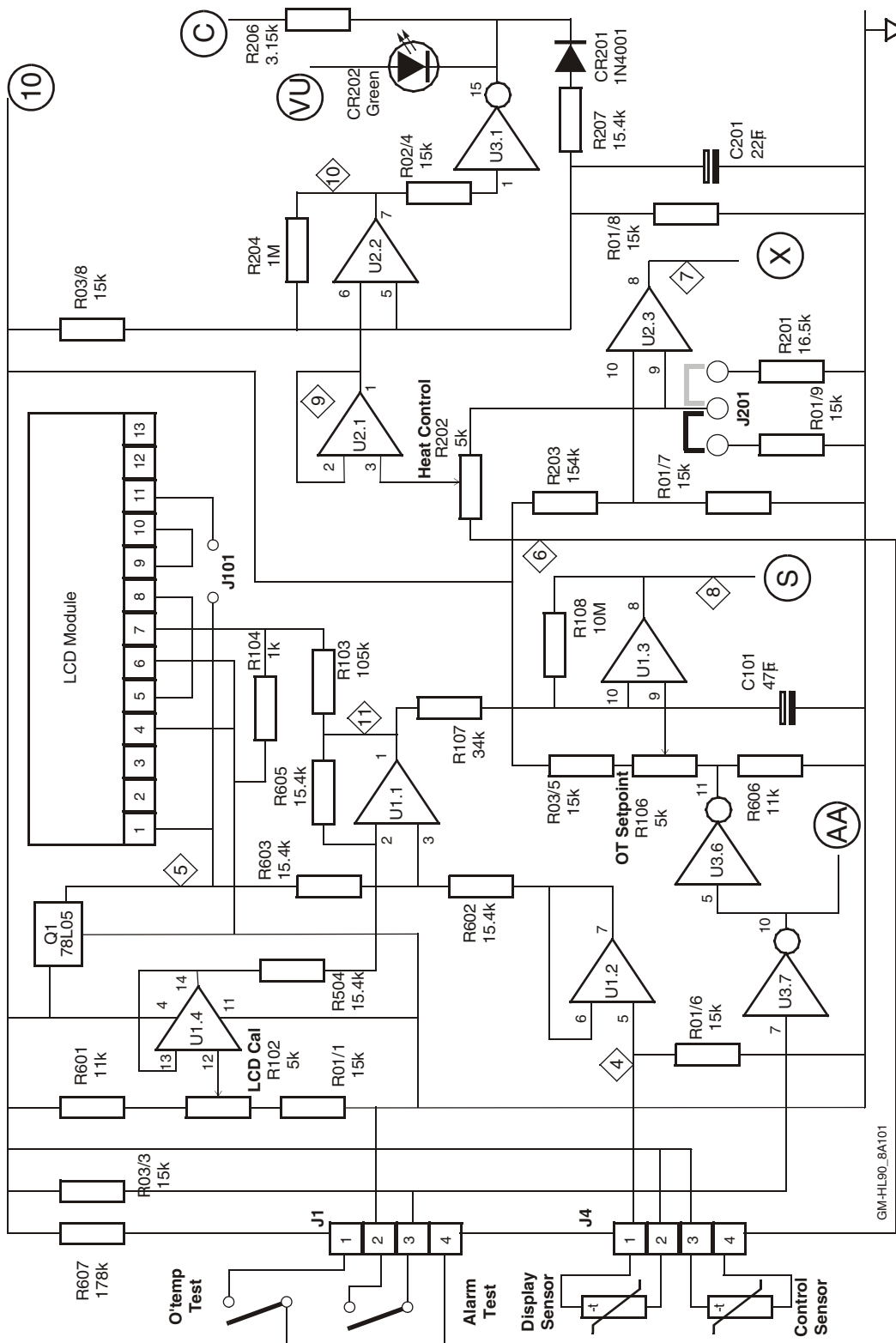

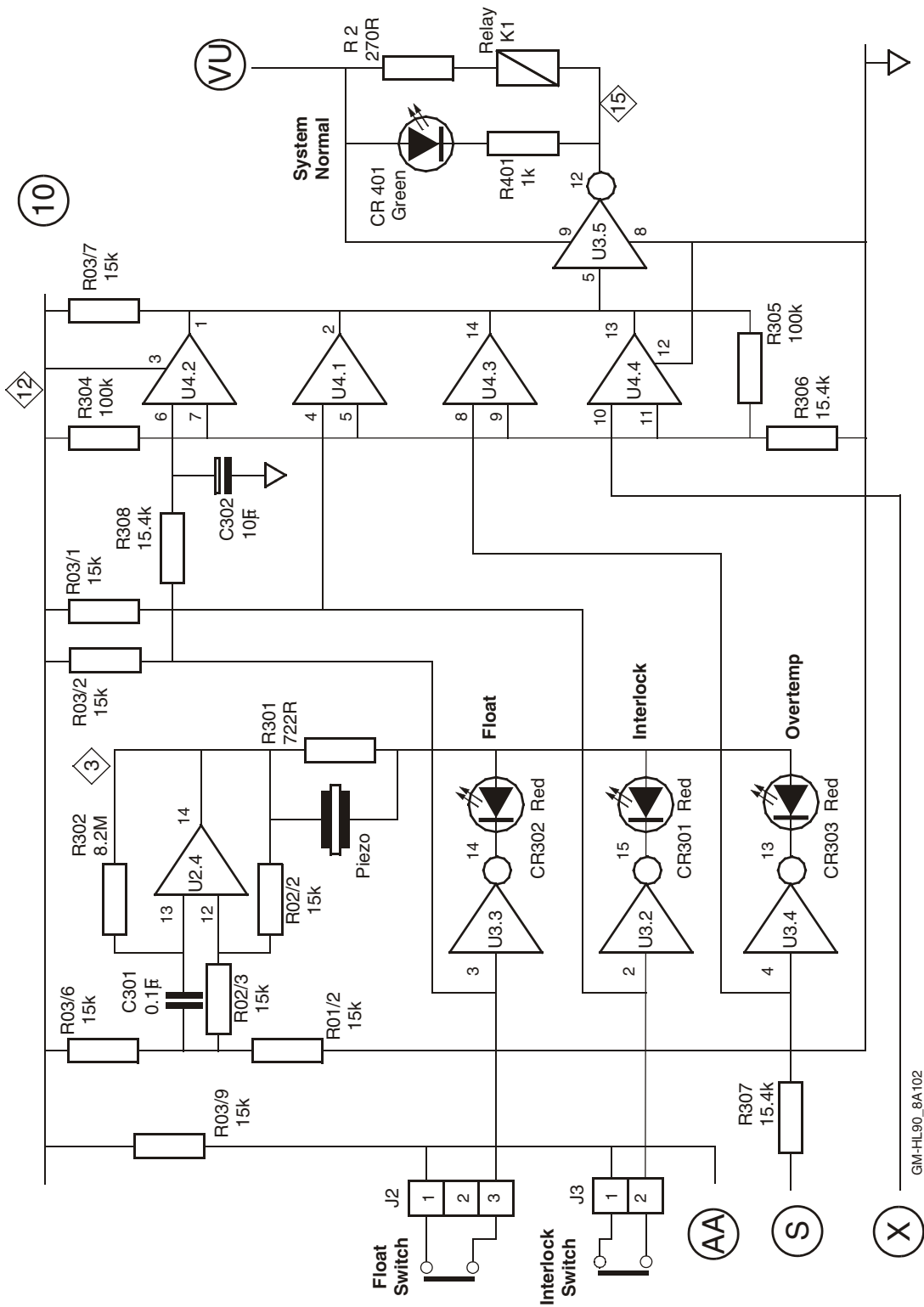



smiths

1

Introduction /  
Specifications

2

Sub-Assemblies

3

Technical Description

4

Disassembly Procedures

5

Maintenance, Testing  
and Calibration

6

Troubleshooting

7

Spare Parts

8

Rounding Off

9

Appendix 1 -  
Circuits

10

Appendix 2 -  
PCB Layout

11

Appendix 3 -  
Symbols Glossary

12

Appendix 4 -  
Frequently Asked Questions  
Information Bulletins



**HOTLINE®**

Blood and  
Fluid Warmer

# PCB layout

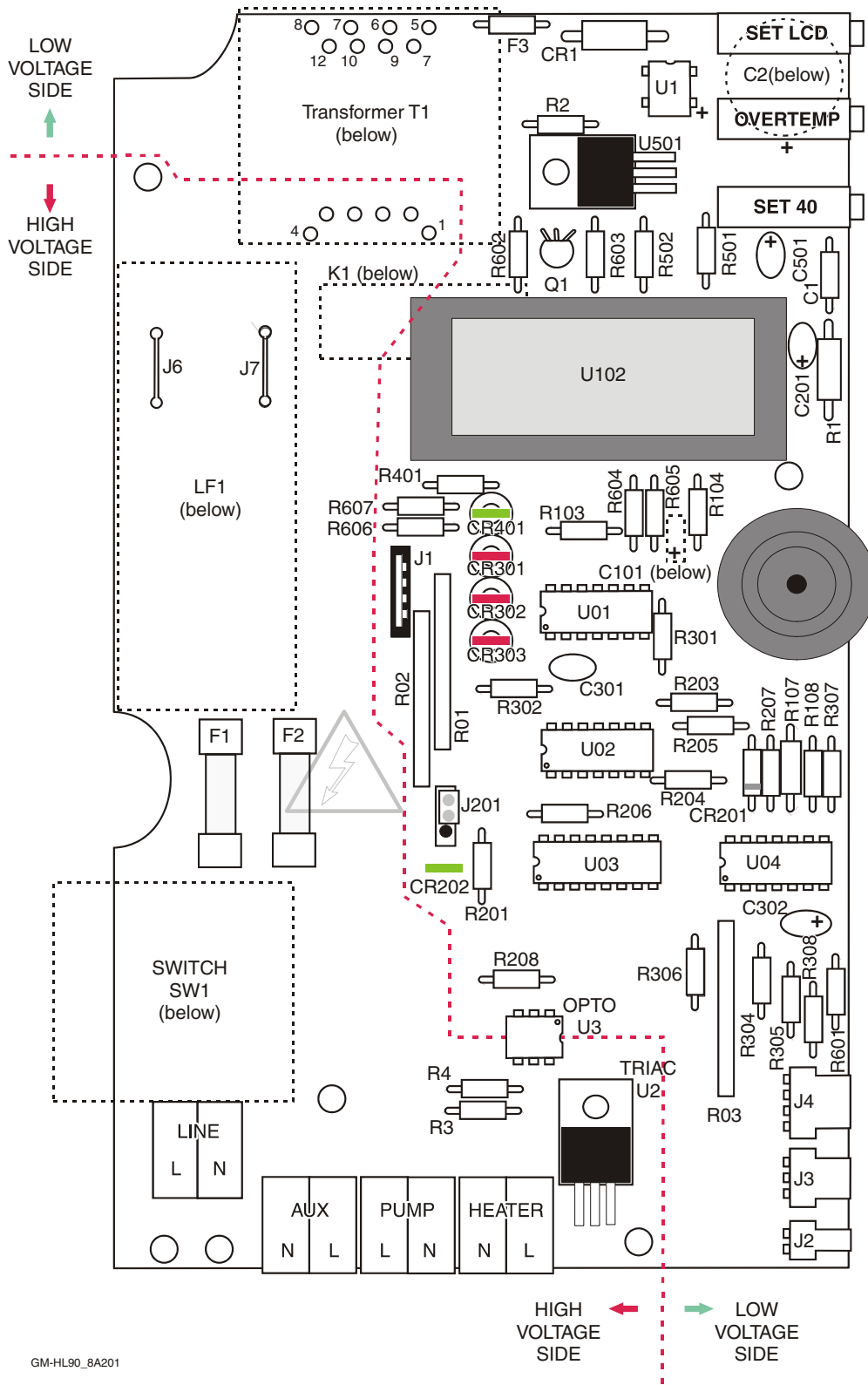

## Component Listing

- This listing is for information only. None of the parts listed below are offered by Smiths Medical as spare parts.
- For the complete list of all available spare parts, please see section 6.

Semiconductors			
U01	LP324N Quad Op-amp	CR1	34V Diac
U02	LP324N Quad Op-amp	CR201	1N4001
U03	Octal Darlington Driver	CR202	Green LED
U04	LP339 Quad Comp	CR301	Red LED
U1	Bridge Rectifier	CR302	Red LED
U2	Triac	CR303	Red LED
U3	Opto-coupler	CR401	Green LED
U501	LM317T Regulator		
Q1	78L05 Regulator		



Resistors					
R01	15k x 9 way	R201	16K5	R401	1K
R02	15k x 7 way	R202	5K POT	R501	433R
R03	15k x 9 way	R203	154K	R502	3.16K
		R204	1M	R503	-
R1	10M	R205	15K4	R504	-
R2	270R	R206	3K16	R505	-
R3	270R	R207	15K4	R506	-
R4	1K	R208	2K	R507	178K
R101					
R102	5K POT	R301	722R	R601	11K
R103	105K	R302	8M2	R602	15K4
R104	1K	R303	-	R603	15K4
R105		R304	100K	R604	15K4
R106	5K POT	R305	100K	R605	15K4
R107	34K	R306	15K4	R606	1K
R108	10M	R307	15K4		

Capacitors		Miscellaneous	
C1	100 pF	LS301	Piezo-Sounder
C101	47 $\mu$ F		
C2	220 $\mu$ F		
C201	22 $\mu$ F		
C301	0.1 $\mu$ F		
C302	10 $\mu$ F		
C501	10 $\mu$ F		

smiths

1

Introduction /  
Specifications

2

Sub-Assemblies

3

Technical Description

4

Disassembly Procedures

5

Maintenance, Testing  
and Calibration

6

Troubleshooting

7

Spare Parts

8

Rounding Off

9

Appendix 1 -  
Circuits

10

Appendix 2 -  
PCB Layout

11

Appendix 3 -  
Symbols Glossary

12







Appendix 4 -  
Frequently Asked Questions  
Information Bulletins







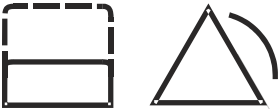

**HOTLINE®**

Blood and  
Fluid Warmer

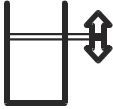
# Symbols Glossary

Symbol	Meaning
	<p>Read Instructions before use or (failing that)                      Disposable Interlock Alarm. The Warming Set is not connected correctly, and must be reattached before proceeding.</p>
	<p>Degrees Celsius</p>
	<p>Recirculating solution temperature</p>
	<p>Operating normally.                      Recirculating solution is being warmed and circulated</p>
	<p>Recirculating solution Level Alarm.                      To clear alarm you must add recirculating solution to the reservoir.</p>
	<p>Over Temperature Alarm.                      Unit must be serviced by a trained technician prior to reuse.</p>
	<p>General Alarm Test Button that simulates the Over Temperature, Low Recirculating Solution and Interlock Alarm conditions. The alarm lamps should all flash, and the audible alarm should sound repetitively.</p>

Symbol	Meaning
	<p>Test Button that simulates the Over Temperature Alarm condition. The Over Temperature Alarm lamp should light up, and the audible alarm should sound repetitively.</p>
	<p>Recirculating solution Level, Minimum and Maximum (current symbols)</p>
	<p>Water Level, Minimum and Maximum (historic symbol)</p>
	<p>Alternating Current</p>
	<p>Type BF applied part</p>
<p><b>IPX1</b></p>	<p>Protected against Dripping Water</p>
	<p>Electrical Shock Hazard. Only trained personnel should open this apparatus.</p>
	<p>Date of Manufacture</p>

smiths

1

Introduction /  
Specifications

2

Sub-Assemblies

3

Technical Description

4

Disassembly Procedures

5

Maintenance, Testing  
and Calibration

6

Troubleshooting

7

Spare Parts

8

Rounding Off

9

Appendix 1 -  
Circuits

10

Appendix 2 -  
PCB Layout

11

Appendix 3 -  
Symbols Glossary

12

Appendix 4 -  
Frequently Asked Questions  
Information Bulletins



**HOTLINE®**

Blood and  
Fluid Warmer

---

## Frequently Asked Questions

These are general Questions and their Answers about various aspects of HOTLINE® operation that, while not technical, others in your establishment may well think you should be able to give them the answer!

- What is the temperature of the intravenous fluid and blood that is delivered to the patient?
  - *Usually about 41°C. With the patented HOTLINE® tubing design, the tubing - the intravenous pathway surrounded by the recirculating solution - is the heat exchanger for the system. The intravenous line is jacketed by the recirculating solution, warming the infusate fluid or blood all the way to the patient. Because heat is exchanged all along the patient line, the infusate temperature is dependent on the flow rate that you set for the intravenous infusion.*
  - *Other warming systems typically warm fluid and blood between warming plates inside the machine. As the warmed fluid or blood flows through the tubing toward the patient it loses most of the amassed heat to the ambient air - which is termed "patient line cool-down."*
  
- Am I overheating intravenous solutions and blood by warming at 42°C?
  - *Effective 1997, the American Association of Blood Banks changed its blood warming temperature threshold. Section J8.200 of the 19th Edition of the AABB's Standards for Blood Banks and Transfusion Services states, "When blood is*

*warmed, it must be done so as not to cause hemolysis." In the abstract, "The Effect of Heat on In-Vitro Parameters of Red Cell Integrity", presented at the 46th Annual Meeting of the AABB, Uhl, Pacini and Kruskall state that "subtle alterations in red cell integrity are not apparent until 46°C and frank hemolysis not until 48°C."*

- *All Level 1<sup>®</sup> Fluid Warming Systems' heat exchanger set point temperatures are established in accordance with this standard. The primary temperature control circuit limits the recirculating solution temperature to 42°C. The fluid in the HOTLINE<sup>®</sup> disposable tubing remains well within the acceptable range. Because the recirculating solution automatically shuts down in the unlikely event of an over temperature situation, the blood or intravenous fluid in the HOTLINE<sup>®</sup> Warming Set would also remain in the acceptable range.*
  
- Some patients and clinicians are sensitive to latex. Do Level 1<sup>®</sup> products, specifically the disposable tubing sets, contain any latex?
  - *Level 1<sup>®</sup> fluid warming machines have no external latex parts, and apart from the L-10 Gas Vent, no HOTLINE<sup>®</sup> disposables or accessories contain latex.*
  
  - *Listed in the Level 1<sup>®</sup> Latex Letter are the disposable products that are currently "latex-free," and if applicable, a transition lot number for when they became latex-free is indicated in parenthesis. Also listed are the disposable products that do contain latex.*



- What is the maintenance requirement on my Level 1® HOTLINE® fluid warmer?
  - *If you operate your HOTLINE® with distilled water as the recirculating solution, the following maintenance will be needed:*
    - *Monthly:*  
*Lubricate the O-Rings with silicone lubricant*  
*Change the distilled water*  
*Disinfect the recirculating solution path*
    - *Annually:*  
*O-Rings should be changed*  
*Test the fault condition alarms*  
*Verify the temperature calibration*
  - *If you operate your HOTLINE® with an approved microbicial solution as the recirculating solution (as recommended by Smiths Medical), the following maintenance will be needed:*
    - *Monthly:*  
*Lubricate the O-Rings with silicone lubricant*
    - *Annually:*  
*Change the recirculating solution*  
*O-Rings should be changed*  
*Test the fault condition alarms*  
*Verify the temperature calibration*
  - *Complete maintenance procedures are provided in all Operator's & Service Manuals.*

■ Is my disposable sterile?

- *All Level 1<sup>®</sup> IV disposables are labeled with "sterile fluid paths" only. Level 1<sup>®</sup> IV disposables should not be passed into a sterile field. Level 1<sup>®</sup> irrigating disposables, however, do include a sterile patient line, which can be passed into a sterile field.*

■ How can I be sure that the recirculating solution won't mix with the IV fluid in my L-70 disposable?

- *The L-70 triple lumen tubing is a single extrusion tube and the connectors are solvent bonded to the tubing. The plastics actually fuse together, so neither the tubing nor the connectors can "come apart" or become "unglued." It is important to follow the Instructions for Use to ensure the integrity of the tubing is confirmed every time an L-70 is set up. Important steps to remember are:*

*[i] Priming the recirculating solution path before connecting to the intravenous administration set.*

*[ii] Inspecting the patient end of the tubing for leaks will confirm integrity of the line.*

*[iii] Do not kink the warming set tubing.*

*[iv] Do not restrict solution circulation through the tubing.*



---

## HOTLINE® - Specific Announcements

#	Topic	Original Format	Page
1	Extension of Maintenance Cycle to 6 months	Customer Letter	8
2	Extension of Maintenance Cycle to 12 months	Customer Letter	10
3	Extension of Maintenance Cycle to 12 months	Web Announcement	13
4	Concerning the degrading of the Foam Washer Sealing the Float Switch Body	ECRI Alert Response	14



July 10, 2003

Dear Customer:

Level 1, Inc.

160 Weymouth Street  
Rockland, MA02370, USA  
Tel: (1) 781 878 8011  
Fax: (1) 781 878 8201  
www.smiths-level1.com

## HOTLINE®: THE BEST JUST GOT BETTER!

HOTLINE, the leading blood and fluid warmer for routine surgical procedures has just gotten better! In addition to HOTLINE's superior performance at delivering warm patients, Level 1 now offers a new Water Bath Maintenance Protocol\* that reduces cleaning maintenance from 12 times a year to only 2 times a year!

## 6-MONTH HOTLINE® WATER BATH MAINTENANCE BENEFITS

The new 6-month protocol\* for the HOTLINE Water Bath will:

- **Maintain a microbe-free environment**
  - HOTLINE uses a disinfecting procedure, unlike hotplate warmers which only use superficial cleaning that does not disinfect or sterilize
- **Reduce yearly maintenance time by >80%**
  - HOTLINE uses a 6-month cleaning procedure, unlike hotplate warmers which require monthly cleaning procedures
- **Reduce yearly maintenance costs**
  - HOTLINE only requires cleaning maintenance costs 2 times a year, unlike hotplate warmers which require cleaning maintenance costs 12 times a year

\*Data on file

smiths

Figure A4 - 1: Extension of the maintenance interval to 6 months - page 1



Level 1, Inc.

160 Weymouth Street  
Rockland, MA02370, USA  
Tel: (1) 781 878 8011  
Fax: (1) 781 878 8201

## 6-MONTH HOTLINE® WATER BATH MAINTENANCE PROTOCOL \*

The new 6-month maintenance solution is a 0.3% hydrogen peroxide/distilled water solution. The protocol below should be followed every 6 months and for HOTLINE's initial setup

:

1. To prepare 0.3% hydrogen peroxide/distilled water solution for a 1.4 litre HOTLINE water bath, mix 140 ml of 3% hydrogen peroxide solution and 1,260 ml of distilled water.
2. Fill HOTLINE Water Bath with 1.4 litres of 0.3% hydrogen peroxide/distilled water solution.
3. Insert a HOTLINE Warming Set (L-70 or L-70 NI) into the HOTLINE Unit.
4. Turn the HOTLINE Unit on and let the solution circulate for 30 minutes.
5. Switch the unit off and empty HOTLINE Water Bath. Discard HOTLINE Warming Set according to established hospital procedures.
6. Refill the HOTLINE Water Bath with 1.4 litres of 0.3% hydrogen peroxide/distilled water solution. It is now ready for operational use.
7. During the 6-month period, any solution lost from the HOTLINE Water Bath through the disposable must be topped off with the same solution i.e. 0.3% hydrogen peroxide/distilled water solution.

If you would like additional information, please do not hesitate to contact me by telephone at 781-878-8011, ext 251 or by email at [poonam.virdi@smiths-level1.com](mailto:poonam.virdi@smiths-level1.com)

Sincerely

Poonam Virdi  
Product Manager, HOTLINE

\*Data on File

smiths

Figure A4 - 2: Extension of the maintenance interval to 6 months - page 2



**Smiths Medical ASD, Inc.**  
**Anesthesia and Safety Devices Division**  
 160 Weymouth Street  
 Rockland MA 02370 USA  
 Tel: +1 781 878 8011  
 Fax: +1 781 878 8201  
 www.smiths-medical.com

October 1, 2004

Dear Valued Customer,

It has only been one year since the introduction of our 6-month reservoir maintenance protocol for the HOTLINE® Blood and Fluid Warmer. We have been working to extend this protocol to reduce HOTLINE® reservoir maintenance from twice a year to once a year, and to reduce the maintenance for the Level 1® Fast Flow Fluid Warmer, from 12 times a year to once a year\*.

**Smiths Medical ASD, Inc. is pleased to announce the new**

**ONE-YEAR MAINTENANCE PROTOCOL**  
**for HOTLINE® Blood and Fluid Warmer and Level 1® Fast Flow Fluid Warmer**

**Benefits for you:**

- **Maintain a microbe-free environment**  
 We use a disinfecting procedure, unlike hotplate warmers which use superficial cleaning that does not disinfect or sterilize.
- **Maintenance time is reduced for the HOTLINE® Warmer from twice a year to once a year and for the Level 1® Fast Flow Fluid Warmer from 12 times a year to once a year**  
 Using hydrogen peroxide mixing bottles will make for easier mixing, pouring and storage of the 0.3% hydrogen peroxide/distilled water solution. To find out more about the mixing bottles please contact your local sales representative or Customer Service at 800-258-5361.
- **Yearly maintenance costs are reduced**  
 The HOTLINE® Warmer and the Level 1® Fast Flow Fluid Warmer require cleaning maintenance costs only once a year, unlike hotplate warmers which may require cleaning maintenance costs up to 12 times a year.

If you would like additional information regarding the new one-year maintenance protocol for the HOTLINE® Blood and Fluid Warmer and/or the Level 1® Fast Flow Fluid Warmer, please do not hesitate to contact us at the below numbers.

Technical Support	1-800-553-8351, prompt 5	TECHSERV@smiths-medical.com
Jill Goudreau	1-800-553-8351 x7893	jill.goudreau@smiths-medical.com
Poonam Viridi, Product Manager	1-800-553-8351 x7851	poonam.virdi@smiths-medical.com

Sincerely,  
 Jill C. Goudreau  
 Associate Product Manager, Fluid Warming

\*Data on file

**Portex® Bivona® Level 1® DHD®**

*Figure A4 - 3: Extension of the maintenance interval to 12 months - page 1*



## ONE-YEAR RESERVOIR MAINTENANCE PROTOCOL

The one-year maintenance solution is a 0.3% hydrogen peroxide/distilled water solution. The below protocol should be followed annually for the Level 1® Fast Flow Fluid Warmer (H-1200, H-1025, H-1000, H-1100), as well as for the initial set up in your facility.

### Level 1® Fast Flow Fluid Warmer

To prepare 0.3% hydrogen peroxide/distilled water solution for the reservoir, mix 140 mL of 3% hydrogen peroxide solution and 1,260 mL of distilled water.

1. Empty reservoir of current solution.
2. Place a container under the drain valve of the Level 1® Fast Flow Fluid Warmer.
3. Drain the re-circulating solution by turning the drain valve clockwise 90 degrees.
4. When all of the re-circulating solution has drained from the unit, close the drain valve.
5. Refill the unit with 1.4 liters of fresh 0.3% hydrogen peroxide/distilled water solution.
6. Insert a D-series disposable set (D-50/DI-50, D-60HL/DI-60HL, D-100/DI-100, D-300/DI-300) into the Level 1® Fast Flow Fluid Warmer. If you use a Level 1® Fast Flow Fluid Warmer for urological and/or gynecological procedures, insert an IR-series disposable set (IR-500, IR-600/IRI-600/IRI-600B, IR-700, IR-40).
7. Turn the unit on and run for a 30-minute disinfection period.
8. Switch the unit off, discard the disposable according to established hospital procedures and empty the reservoir of the re-circulating solution by turning the drain valve clockwise 90 degrees. When all of the re-circulating solution has been drained from the unit, close the drain valve.
9. Refill the reservoir with 1.4 liters of fresh 0.3% hydrogen peroxide/distilled water solution. The Level 1® Fast Flow Fluid Warmer is now ready for use.

**During the 12-month period, any solution lost from the reservoir through the disposable must be topped off with the 0.3% hydrogen peroxide/distilled water solution.**





## ONE-YEAR RESERVOIR MAINTENANCE PROTOCOL

The one-year maintenance solution is a 0.3% hydrogen peroxide/distilled water solution. The below protocol should be followed annually for the HOTLINE® Blood and Fluid Warmer (HL-90), as well as for the initial set up in your facility.

### HOTLINE® Blood and Fluid Warmer

To prepare 0.3% hydrogen peroxide/distilled water solution for the reservoir, mix 140 mL of 3% hydrogen peroxide solution and 1,260 mL of distilled water.

1. Empty solution currently in HOTLINE® Warmer reservoir.
2. Fill the reservoir with 1.4 liters of fresh 0.3% hydrogen peroxide/distilled water solution.
3. Insert a disposable set (L-70 or L-70 NI) into the HOTLINE® Warmer.
4. Turn the unit on and let the solution circulate for a 30-minute disinfection period.
5. Switch the unit off and empty the reservoir. Discard the disposable according to established hospital procedures.
6. Refill the reservoir with 1.4 liters of fresh 0.3% hydrogen peroxide/distilled water solution. The HOTLINE® Blood and Fluid Warmer is now ready for use.

**During the 12-month period, any solution lost from the reservoir through the disposable must be topped off with the 0.3% hydrogen peroxide/distilled water solution.**

---

## ONE-YEAR MAINTENANCE PROTOCOL for HOTLINE<sup>®</sup> Blood and Fluid Warmers

### Benefits for you:

- *Maintain a microbe-free environment*

We use a disinfecting procedure, unlike hotplate warmers which use superficial cleaning that does not disinfect or sterilize.

- *Maintenance time is reduced for the HOTLINE<sup>®</sup> Warmer from twice a year to once a year*

Using hydrogen peroxide mixing bottles will make for easier mixing, pouring and storage of the 0.3% hydrogen peroxide/distilled water solution. To find out more about the mixing bottles please contact your local sales representative or Customer Service at 800-258-5361.

- *Yearly maintenance costs are reduced*

The HOTLINE<sup>®</sup> Warmer requires cleaning maintenance costs only once a year, unlike hotplate warmers which require cleaning maintenance costs 12 times a year.

### ONE-YEAR HOTLINE<sup>®</sup> MAINTENANCE PROTOCOL\*

The one-year maintenance solution is a 0.3% hydrogen peroxide/distilled water solution. The below protocol should be followed annually for the HOTLINE<sup>®</sup> Blood and Fluid Warmer (HL-90), as well as for the initial set up in your facility.

To prepare 0.3% hydrogen peroxide/distilled water solution for the reservoir, mix 140 mL of 3% hydrogen peroxide solution and 1,260 mL of distilled water.

- 1) Empty solution currently in HOTLINE<sup>®</sup> Warmer reservoir.
- 2) Fill the reservoir with 1.4 liters of fresh 0.3% hydrogen peroxide/distilled water solution.
- 3) Insert a disposable set (L-70 or L-70 NI) into the HOTLINE<sup>®</sup> Warmer.
- 4) Turn the unit on and let the solution circulate for a 30-minute disinfection period.
- 5) Switch the unit off and empty the reservoir. Discard the disposable according to established hospital procedures.
- 6) Refill the reservoir with 1.4 liters of fresh 0.3% hydrogen peroxide/distilled water solution. The HOTLINE<sup>®</sup> Blood and Fluid Warmer is now ready for use.

During the 12-month period, any solution lost from the reservoir through the disposable must be topped off with the 0.3% hydrogen peroxide/distilled water solution.

---

---

# Memorandum

**Smiths Medical ASD, Inc.**  
**Anesthesia and Safety Devices Division**  
160 Weymouth Street  
Rockland MA 02370 USA  
Tel: 781 878 8011  
Fax: 781 878 8201  
www.smiths-medical.com

TO: CC Sales East; CC Sales West; Alternate Care; Paul Bennett; Philip Spiegel; Mike Devine; CC Marketing; Tech Support; Customer Service; RAQA; Rick Ellis; AI Pul-sifer

FROM: Jill Goudreau, Associate Product Manager- Fluid Warming

SUBJECT: ECRI Alert ***“New Peroxide Cleaning Protocol Causes Degradation of Washer in Level I HOTLINE® Fluid Warmers”***

DATE: August 16, 2005

On July 29th an ECRI User Experience Network Report was released regarding the black foam washer on the float switch in the HOTLINE® Blood and Fluid Warmer. The report states that an ECRI Member hospital reported that the black foam washer on the float switch in the HOTLINE® Blood and Fluid Warmer began disintegrating, turning the circulating solution in the reservoir brown. This problem occurred after the facility switched from using distilled water to the 0.3% Hydrogen Peroxide solution.

Prior to March 2004, we were supplying the HOTLINE® Warmer with a gasket made of neoprene. Since March 2004, the gasket material was changed to silicone as a continual improvement measure. This material has been tested and is compatible with the 0.3% Hydrogen Peroxide solution.

The ECRI alert recommends that customers visually inspect the reservoir (water bath) of all HOTLINE® Blood and Fluid Warmers and proactively replace any black foam washer with the new orange silicone washer. Customers can obtain this new orange silicone washer by calling Technical Support at 800-553-8351. The part number for the orange silicone washer is 62-40-011, and will be provided free of charge. Technical Support will also provide the customer with an updated version of the One-Year Protocol which has been revised to include a statement regarding what to do if you have a HOTLINE® Blood and Fluid Warmer that was shipped prior to March 2004.

If you have any further questions, please contact Technical Support or Laurie Schechter in Rockland at 800-553-8352 x7869.

Your Notes / Diagrams

+

+

+

+

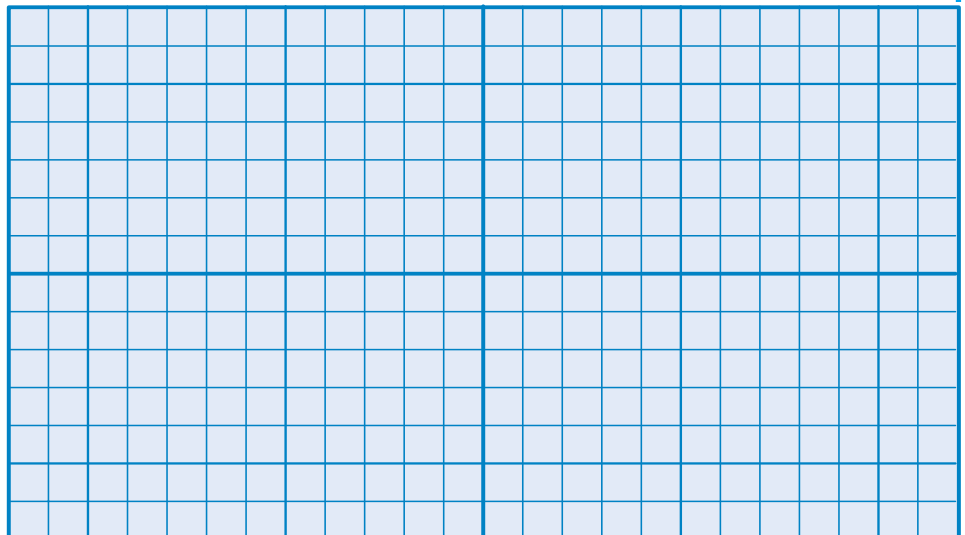

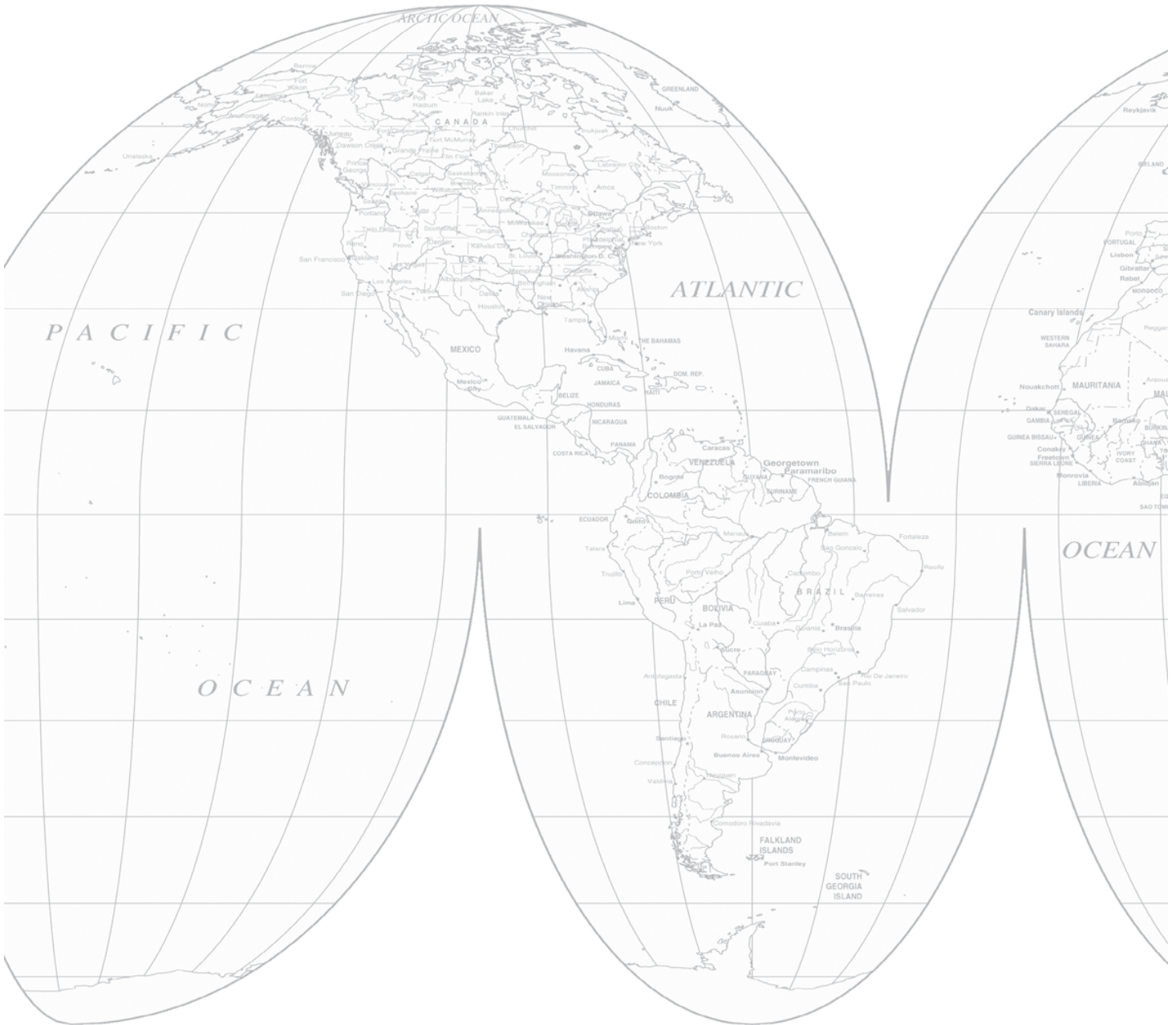

THE DETAILS GIVEN IN THIS MANUAL ARE CORRECT AT THE TIME OF GOING TO PRESS. THE COMPANY, HOWEVER, RESERVES THE RIGHT TO IMPROVE THE EQUIPMENT SHOWN.



**Smiths Medical ASD Inc.,**  
 Rockland, MA 02370, USA  
 Tel:+1 781-878-8011, 1 800-5-LEVEL-1 Fax: +1 781-878-8201



**European Representative: Smiths Medical International Ltd.,**  
 Ashford, Kent, TN25 4BF, UK  
 Tel +44 (0) 1233 722100

**Australian Representative: Smiths Medical Australasia Pty. Ltd.,**  
 Eight Mile Plains, QLD 4113, Australia  
 Tel +61 (0) 7 3340 1300, Fax +61 (0) 7 3340 1399

**www.smiths-medical.com    info@smiths-medical.com**

4534009EN Rev 001 (10/11)

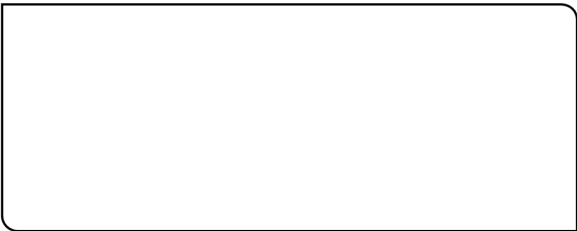

**smiths medical**