

# Technical Service Manual

Fabius GS  
Inhalation Anesthesia Machine



**Revision 3.0**  
**5330.500**  
**9036095**



## General

<b>1</b>	<b>Notes</b>	<b>3</b>
1.1	Symbols and Definitions .....	4

## Function Description

<b>1</b>	<b>General Information about the Fabius GS</b>	<b>7</b>
<b>2</b>	<b>Function diagram of Fabius GS</b>	<b>12</b>
<b>3</b>	<b>Battery backup</b>	<b>14</b>
<b>4</b>	<b>Fabius GS piping diagram</b>	<b>14</b>
<b>5</b>	<b>Function description of gas box</b>	<b>15</b>
<b>6</b>	<b>SORC (Sensitive Oxygen Ratio Controller)</b>	<b>16</b>
<b>7</b>	<b>Cosy 2 breathing system</b>	<b>18</b>
7.1	Ventilation mode .....	22
7.2	Function description: Manual ventilation .....	23
7.3	Function description: Spontaneous breathing .....	27
7.4	Function description: Volume/pressure control ventilation mode .....	31
7.5	Cosy 2 absorber .....	35
<b>8</b>	<b>Ventilator</b>	<b>35</b>
8.1	Safety valve .....	38
8.2	Auxiliary air valve .....	38
<b>9</b>	<b>Pneumatics</b>	<b>39</b>
9.1	PEEP/Pmax valve control .....	39
9.2	APL bypass valve control .....	40

## Contents

<b>10</b>	<b>Electrical block diagram</b>	<b>41</b>
<b>11</b>	<b>Function description: Control PCB</b>	<b>41</b>
<b>12</b>	<b>Control panel assembly</b>	<b>42</b>
<b>13</b>	<b>FiO2 Measurement</b>	<b>44</b>
<b>14</b>	<b>Respiratory Flow Measurement</b>	<b>45</b>
<b>15</b>	<b>Gas flow rate measurement</b>	<b>46</b>
<b>16</b>	<b>Anesthetic vaporizer(s)</b>	<b>47</b>
<b>17</b>	<b>Leak test</b>	<b>49</b>
17.1	System leak test .....	49
17.2	Patient leak test .....	49

## Annex

### Parts catalog

### Technical Information

# General



## 1 Notes

This Technical Documentation conforms to the IEC 60601-1 standard.

Read each step in every procedure thoroughly before beginning any test. Always use the proper tools and specified test equipment. If you deviate from the instructions and/or recommendations in this Technical Documentation, the equipment may operate improperly or unsafely, or the equipment could be damaged.

Use only original Dräger parts and supplies.

The maintenance procedures described in this Technical Documentation may be performed by qualified service personnel only. These maintenance procedures do not replace inspections and servicing by the manufacturer.

The information in this manual is confidential and may not be disclosed to third parties without the prior written consent of the manufacturer.



**Strictly follow the Instructions for Use manual / Operating Instructions! This Technical Documentation does not replace the Instructions for Use manual / Operating Instructions. Any use of the product requires full understanding and strict observation of the product-specific Instructions for Use manual/ Operating Instructions.**



Reference is hereby made to the observance of the relevant safety provisions, for example in Germany, the Medical Product Law (MPG), the Medical Device Operator Ordinance (MPBetreibV), the Pressure Container Ordinance (Druckbehälterverordnung), the Technical Rules for Pressurized Gases (Technische Regeln Druckgase), or the Occupational Health and Safety Provisions (Unfallverhütungsvorschriften).

Unless otherwise stated, reference is made to laws, regulations or standards (as amended) applicable in the Federal Republic of Germany.

Follow the laws and regulations applicable in your country.

## 1.1 Symbols and Definitions



This symbol indicates a warning.



This symbol indicates tips and useful information.



This symbol is used to alert against unsafe practices when handling electrostatic sensitive devices (ESD).

Definitions according to German standard DIN 31051:

Inspection	=	examination of actual condition
Maintenance	=	measures to maintain specified condition
Repair	=	measures to restore specified condition
Servicing	=	inspection, maintenance, and repair



# Function Description



**1 General Information about the Fabius GS**

The Fabius GS comprises the following assemblies:

- Display and Control Panel
- Flowmeter assembly
- Gas box: Gas Inlet Assembly and related items
- Breathing system
- Pneumatic assembly
- Ventilator
- Vaporizers
- Trolley

Monitoring, electrical connections and gas connections as shown in [Figure 1](#), [Figure 2](#), [Figure 3](#), and [Figure 4](#).

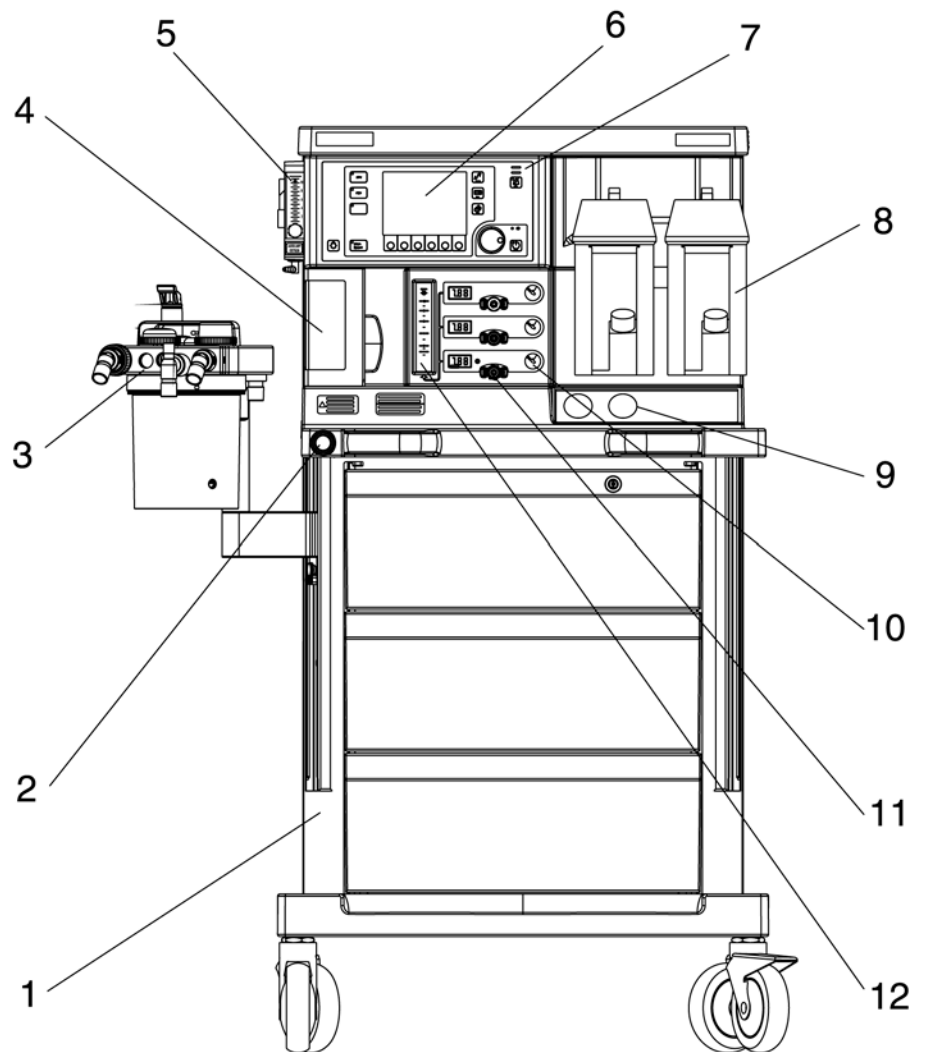

**Figure 1** Front view of Fabius GS anesthesia system, for legend see [Table 1](#)

Table 1 Legend to Figure 1

No.	Name
1	Trolley
2	O2 flush
3	Cosy 2 breathing system
4	Ventilator
5	Oxygen flowmeter (auxiliary)
6	Display
7	Control panel
8	Vaporizers
9	Cylinder Pressure Gauges
10	Pipeline Pressure Gauges
11	Flow Control Valves
12	Total fresh gas flowmeter

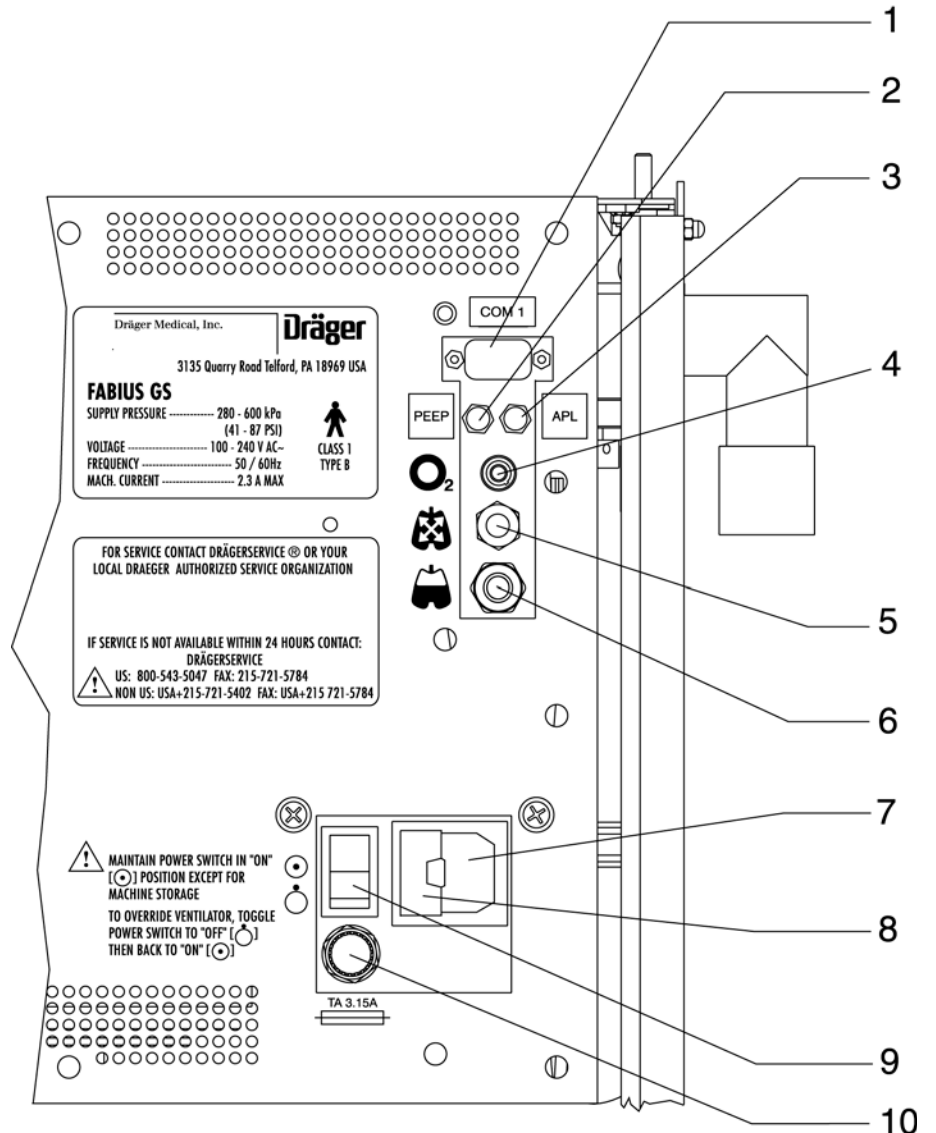
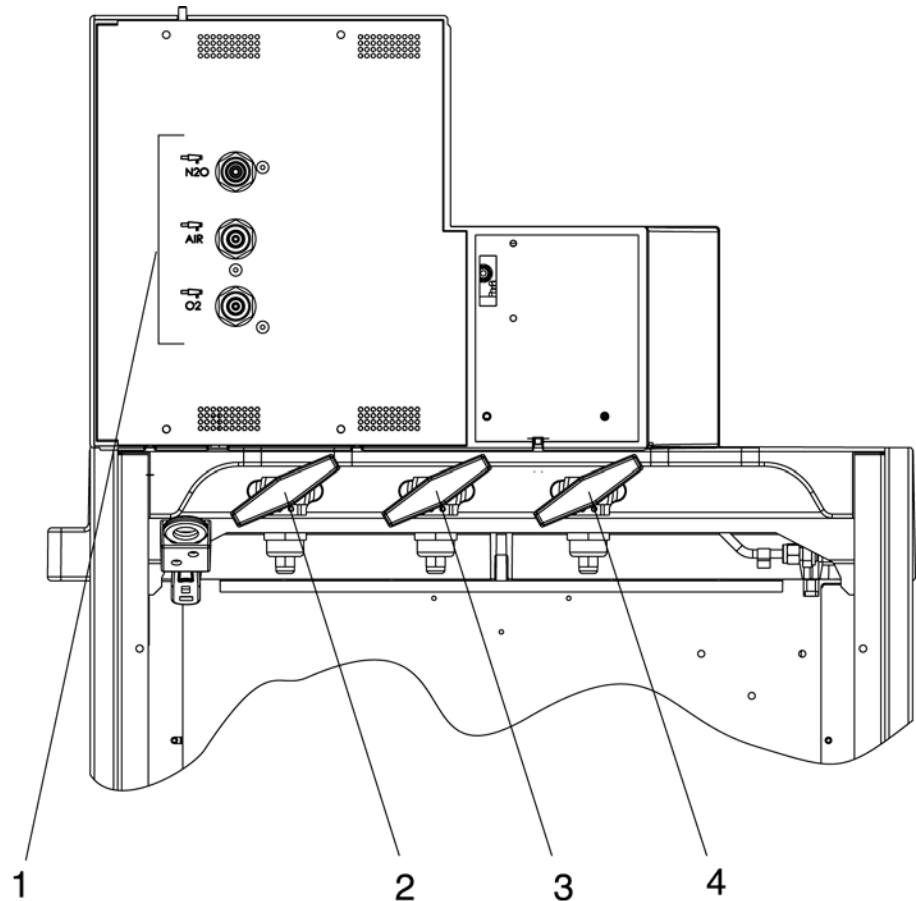

**Figure 2** Rear view showing interface panel and power entry, for legend see [Table 2](#)

**Table 2** Legend to [Figure 2](#)

No.	Name
1	Serial communication ports (only one is shown)
2	Tube connection for PEEP valve
3	Tube connection for APL bypass valve
4	O <sub>2</sub> sensor connection
5	Airway pressure connection
6	Spirolog sensor connection
7	Power entry
8	Cover for power fuses (2x 2.5 A)

No.	Name
9	ON/OFF switch
10	Battery fuse



**Figure 3** Rear view showing gas pipeline and PIN index cylinder connections, for legend see [Table 3](#)

**Table 3** Legend to [Figure 3](#)

No.	Name
1	Pipeline tube connections
2	N2O or AIR PIN index cylinder connections
3	O2 PIN index cylinder connection
4	O2 PIN index cylinder connection

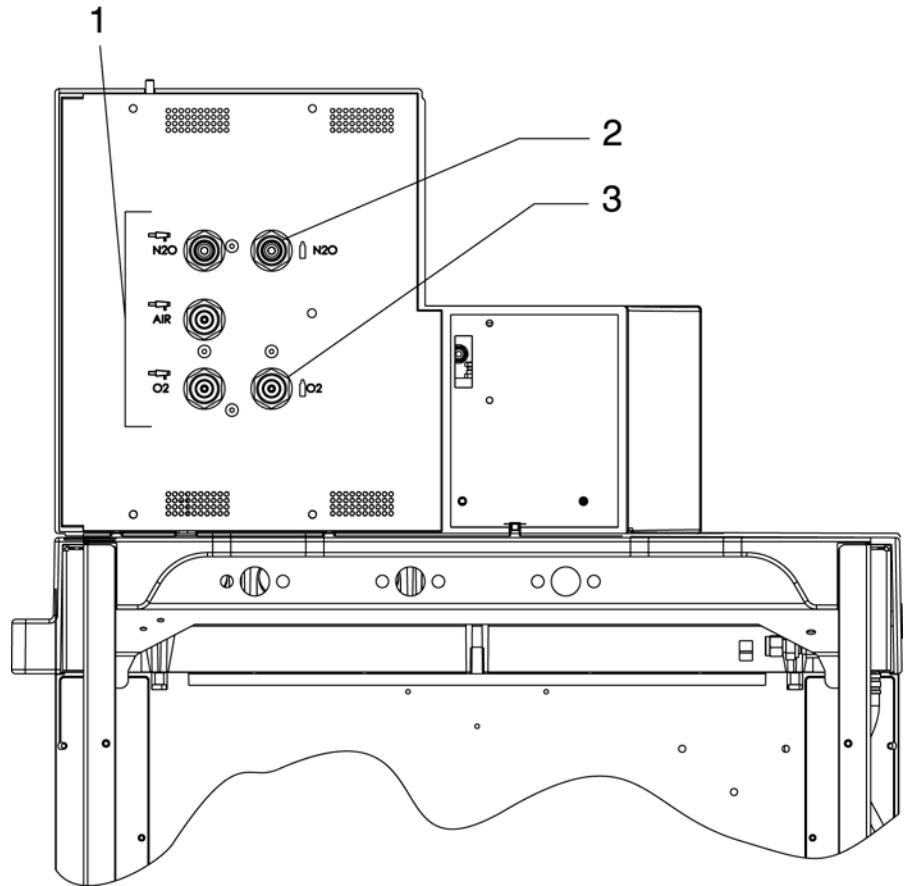

**Figure 4** Rear view showing gas pipeline and cylinder connections (units without PIN index cylinder connections), for legend see [Table 4](#)

**Table 4** Legend to [Figure 4](#)

No.	Name
1	Pipeline tube connections
2	N2O cylinder connection
3	O2 cylinder connection

2 Function diagram of Fabius GS

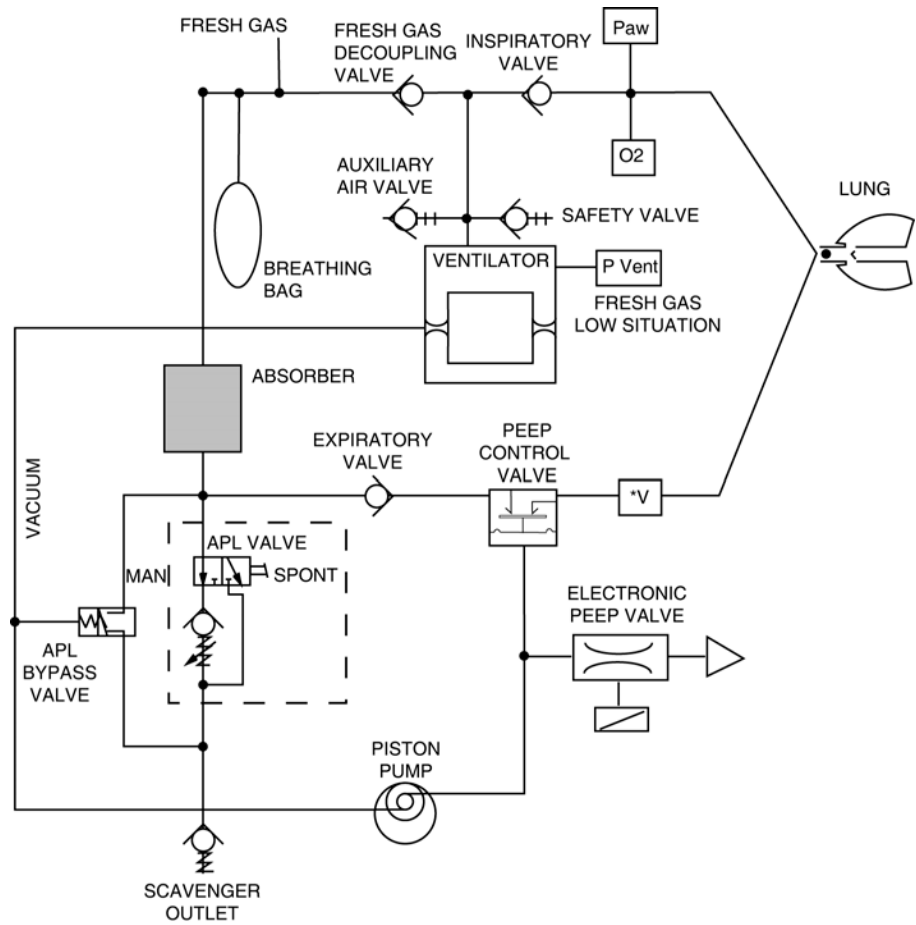
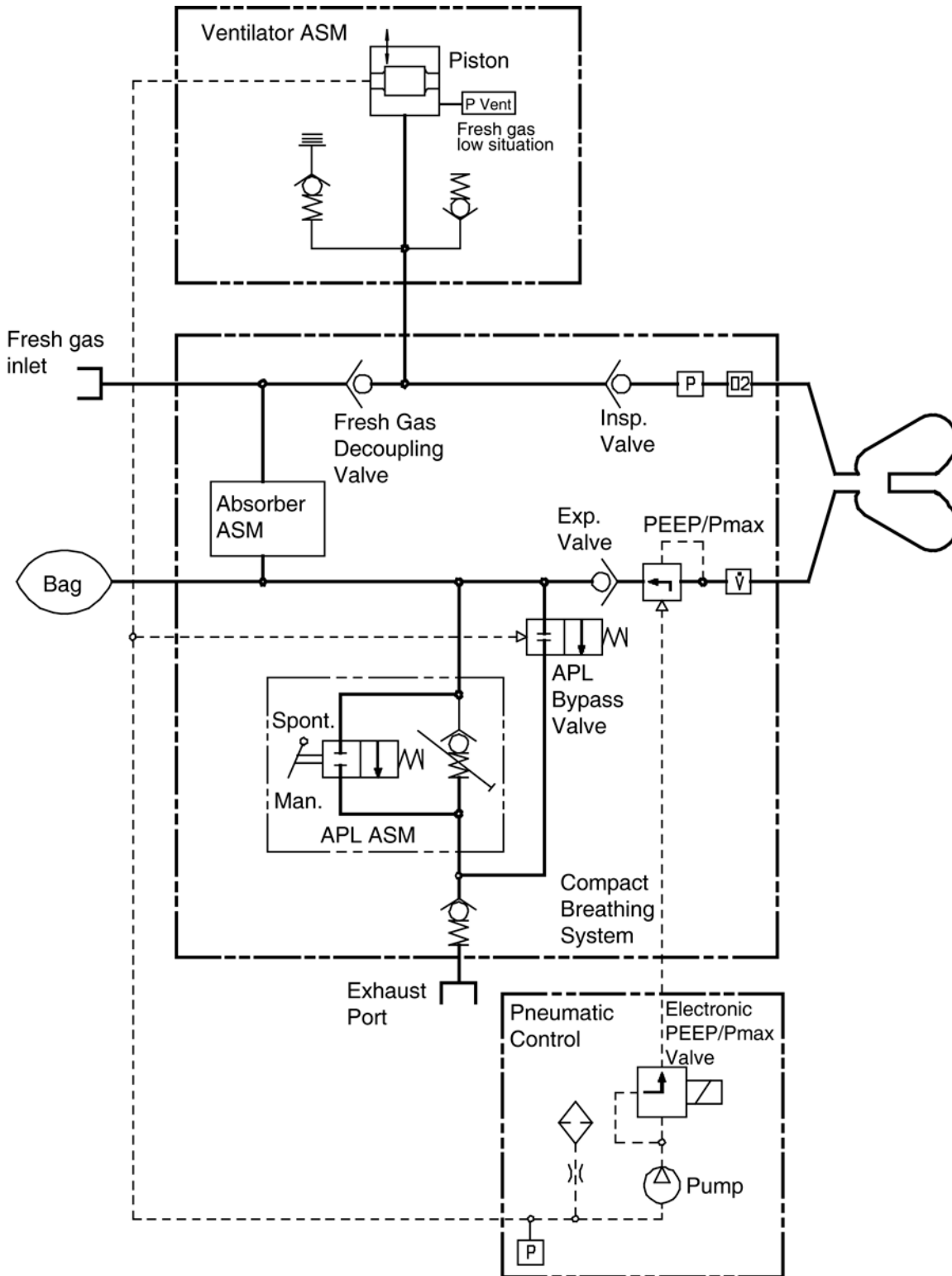

Figure 5 Function diagram of Fabius GS - Cosy 2 breathing system





**Figure 6** Function diagram of Fabius GS - Cosy 2.5 (2.6) breathing system

### 3 Battery backup

Fabius GS backup power is provided by two series-connected 12 V rechargeable batteries. These batteries remain on charge as long as the machine is plugged into an active AC outlet. Should power supply fail while the machine is in operation, the batteries will allow the machine to continue operating for a minimum of 45 minutes, provided that the batteries are fully charged.

The batteries are accessible by opening the ventilator compartment. The 3.15A battery fuse is located at the back of the control box.

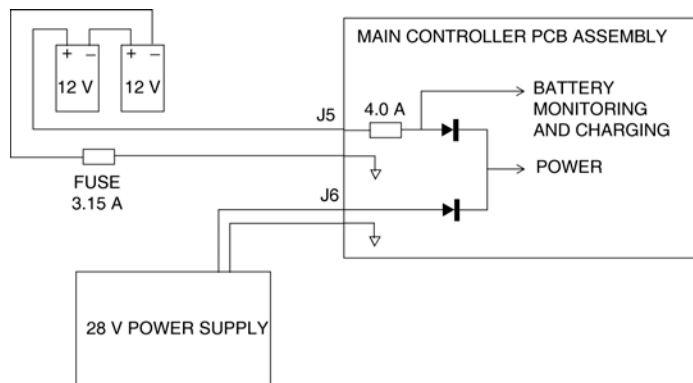

Figure 7 Battery backup arrangement

### 4 Fabius GS piping diagram

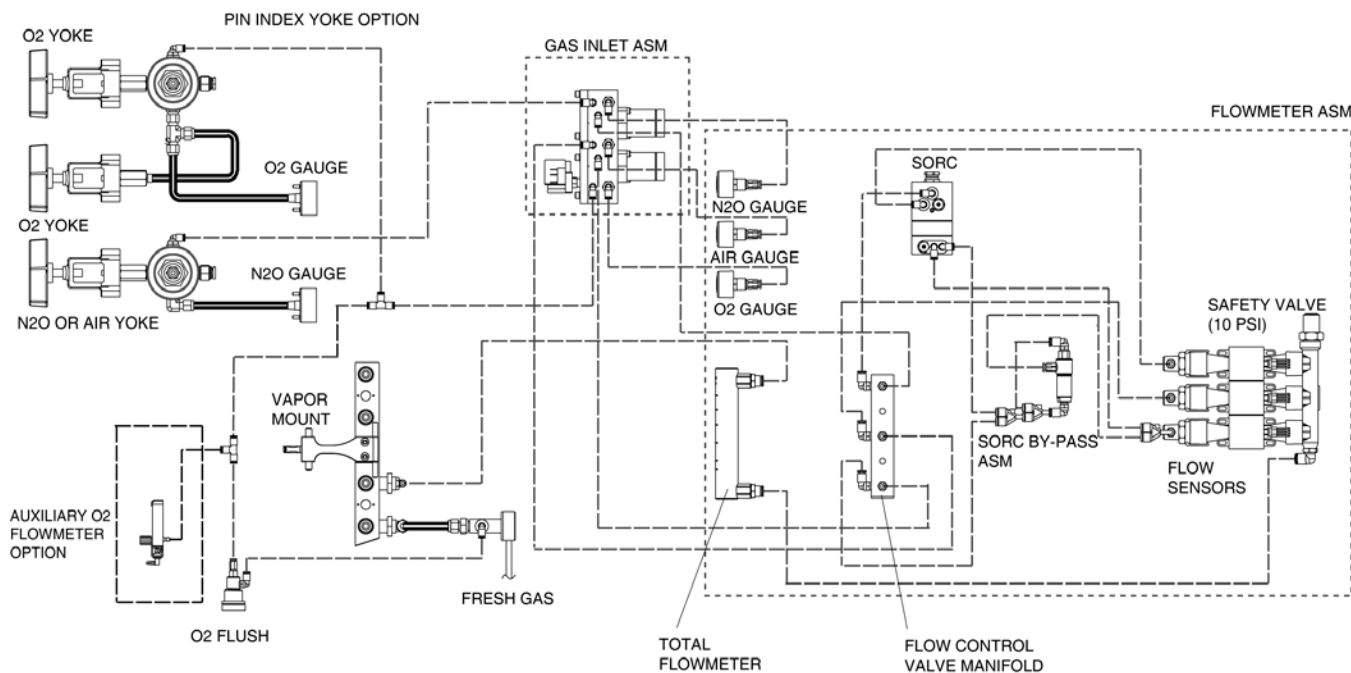
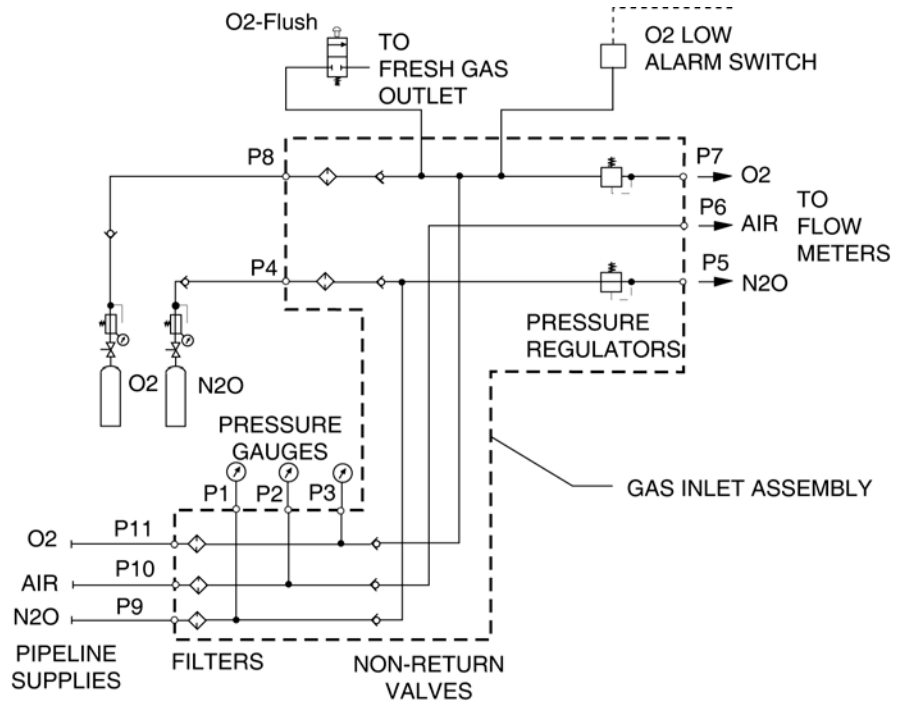

Figure 8 Fabius GS piping diagram

**5 Function description of gas box**

The supply gases flow through the filters and non-return valves in the gas inlet assembly. Pipeline supply pressures are indicated on pipeline pressure gauges located on the flowmeter assembly. Cylinder pressure gauges are located on the trolley assembly. The pressures of O<sub>2</sub> and N<sub>2</sub>O delivered to the flowmeter assembly are set by regulators on the gas inlet assembly.

Should the O<sub>2</sub> supply fail or if its pressure decrease below a certain limit, the O<sub>2</sub> low alarm switch signals an alarm.



**Figure 9** Gas box function diagram, part 1

If the O<sub>2</sub> flush button is pressed, oxygen is delivered to the fresh-gas outlet. The fresh-gas ejector prevents the fresh gas from flowing back into the anesthetic vaporizer. This avoids an increase in the anesthetic gas concentration.

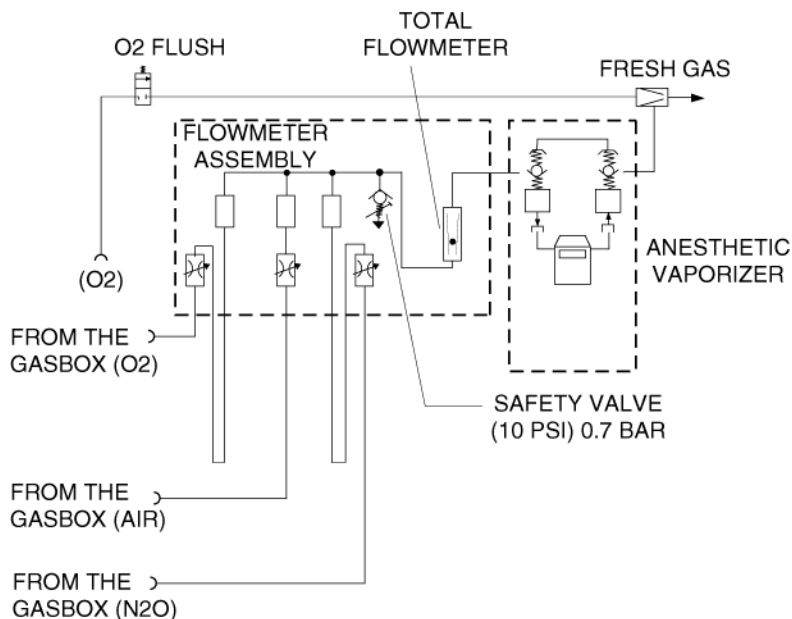

**Figure 10** Gas box function diagram, part 2

**6 SORC (Sensitive Oxygen Ratio Controller)**

The SORC is a control element that functions like an N<sub>2</sub>O shut-off device and ensures a vital O<sub>2</sub> concentration in the fresh gas. In the event of an O<sub>2</sub> shortage, the SORC limits the N<sub>2</sub>O flow such that the O<sub>2</sub> concentration in the fresh gas does not decrease below 21 vol.%.

If the O<sub>2</sub> flow control valve is closed or if the O<sub>2</sub> flow is lower than or equal to 200 mL/min, the SORC interrupts the N<sub>2</sub>O flow.

N<sub>2</sub>O can be added as of an O<sub>2</sub> flow of approx. 300 mL/min. In this case, the SORC also prevents O<sub>2</sub> concentrations below 21 vol.%.

The SORC bypass allows O<sub>2</sub> to bypass the restrictor in the SORC when O<sub>2</sub> flows above 10 L/min are needed.

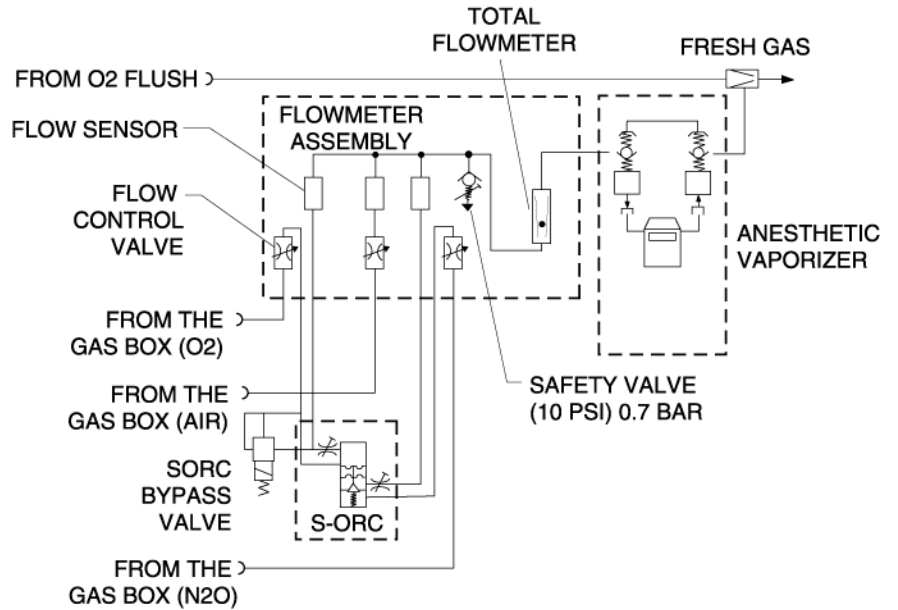

Figure 11 SORC function diagram, part 1

The O<sub>2</sub> and N<sub>2</sub>O flows are adjusted with the flow control valves.

Restrictors located at the outlets of the SORC generate back-pressures. These back-pressures exert a force on the control diaphragms of the SORC. The O<sub>2</sub> back-pressure opens the SORC. The N<sub>2</sub>O back-pressure closes the SORC. The pressure ratio at the control diaphragm affects the N<sub>2</sub>O flow.

The resistors and the spring force are dimensioned such that a minimum concentration of 21 vol.% of O<sub>2</sub> is always ensured. The maximum O<sub>2</sub> flow is approx. 12 L/min.

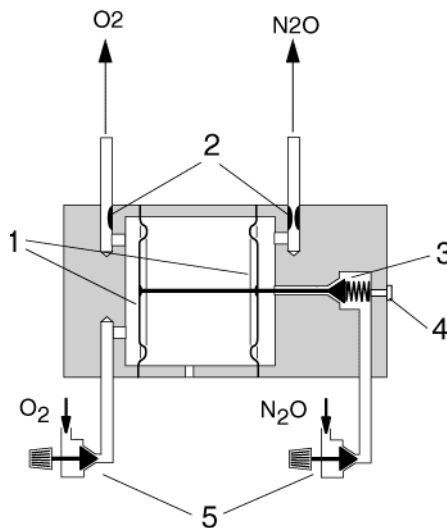

Figure 12 SORC function diagram, part 2, for legend see Table 5

Table 5 Legend to Figure 12

No.	Name
1	Control diaphragms
2	Restrictors
3	N2O non-return valve
4	Operating-point adjusting screw
5	Flow control valves

## 7 Cosy 2 breathing system

The Cosy 2 breathing system allows three modes of patient ventilation:

- Manual ventilation and spontaneous breathing
- Volume controlled ventilation
- Pressure controlled ventilation

The APL valve (adjustable pressure limiting valve), lever type, has a selector switch which can be used to toggle between “MAN” and “SPONT”.

On APL valves with control knob, switching from “IPPV/SPONT” to “MAN” is carried out by turning the knob.

In the “MAN” position, the breathing system is closed to atmosphere. This position is used for manual ventilation of the patient. The APL valve opening pressure can be adjusted from 5 to 70 cmH<sub>2</sub>O (mbar).

In the “SPONT” position the APL valve is open to atmosphere. This position is used for spontaneous breathing.

Using the control box and the PEEP Pmax valve, the pressure limit (Pmax) can also be adjusted during volume control from 15 cmH<sub>2</sub>O (mbar) to 70 cmH<sub>2</sub>O (mbar) via the membrane keypad.

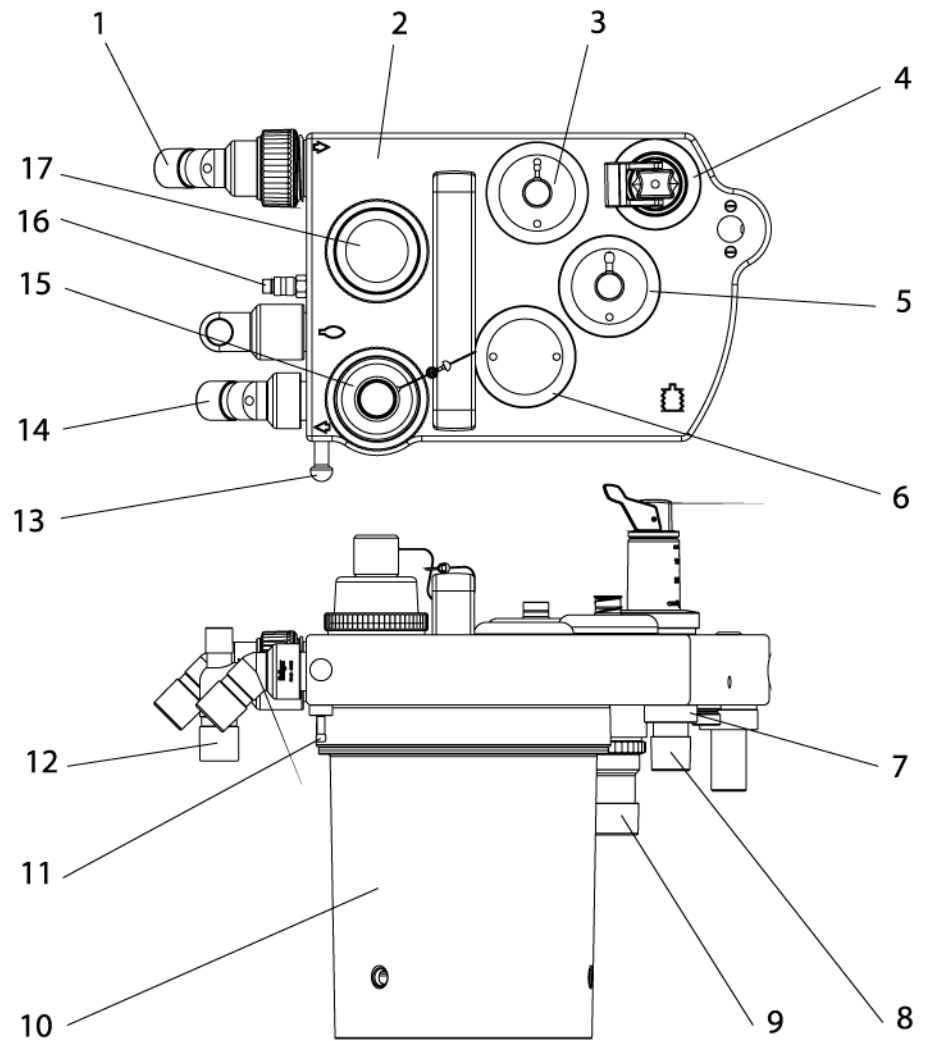

Figure 13 Cosy 2 breathing system, for legend see Table 6

Table 6 Legend to Figure 13

No.	Name
1	Expiratory connection
2	Flow sensor (Spirolog) (not shown)
3	PEEP/Pmax valve
4	MAN/SPONT APL valve
5	APL Bypass valve
6	Fresh-gas decoupling valve
7	Fresh-gas port
8	Ventilator port
9	Anesthetic gas scavenging port
10	Absorber

No.	Name
11	Pressure sensor connection
12	Breathing bag terminal and standby holder for Y-piece
13	Breathing bag hook
14	Inspiratory connection
15	Inspiratory valve and O2 sensor connection
16	Anesthesia monitor return line (only for systems outside the USA)
17	Expiratory valve

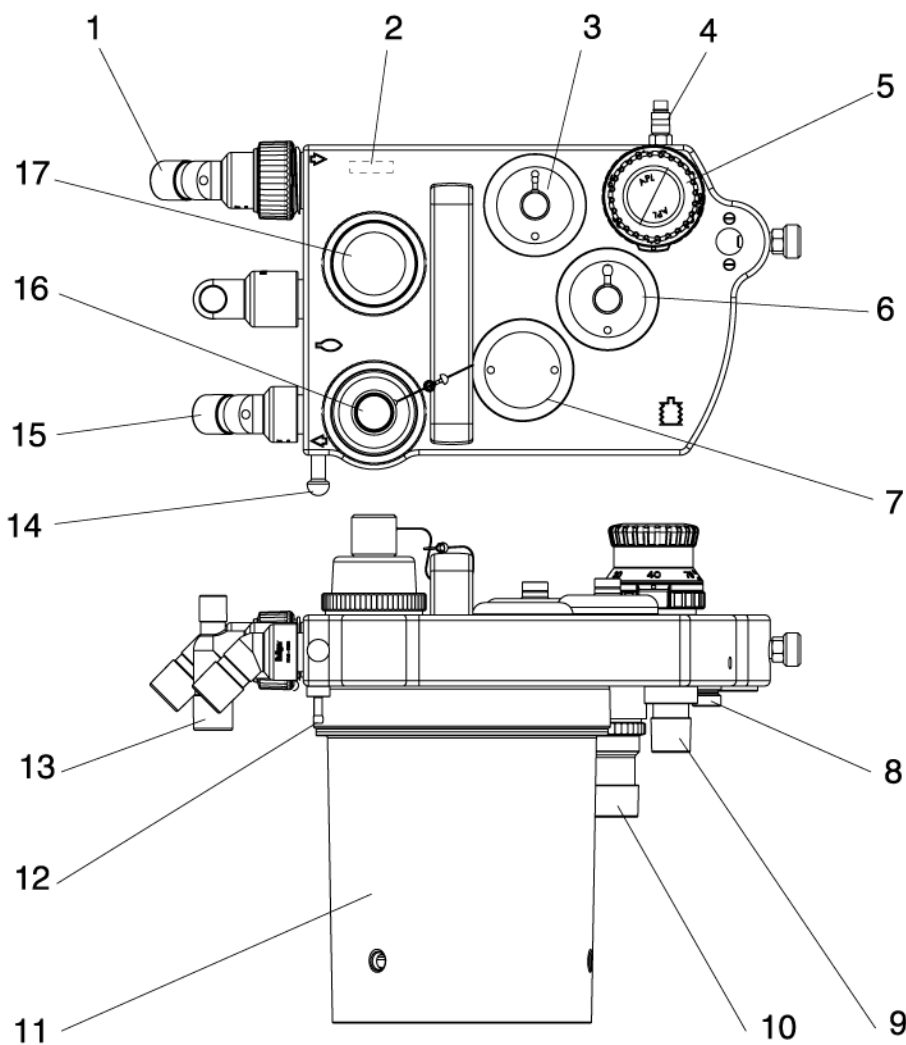

Figure 14 Cosy 2.5 (2.6) breathing system, for legend see Table 7

Table 7 Legend to Figure 14

No.	Name
1	Expiratory connection
2	Flow sensor (Spirolog) (not shown)

All rights reserved. Copyright reserved.  
Version 1.0\_Released\_Printed on\_10.11.05\_F5330500\_Function\_Description.fm



No.	Name
3	PEEP/Pmax valve
4	Anesthesia monitor return line (only for systems outside the USA)
5	MAN/SPONT APL valve
6	APL Bypass valve
7	Fresh-gas decoupling valve
8	Fresh-gas port
9	Ventilator port
10	Anesthetic gas scavenging port
11	Absorber
12	Pressure sensor connection
13	Breathing bag terminal and standby holder for Y-piece
14	Breathing bag hook
15	Inspiratory connection
16	Inspiratory valve and O2 sensor connection
17	Expiratory valve

7.1 Ventilation mode

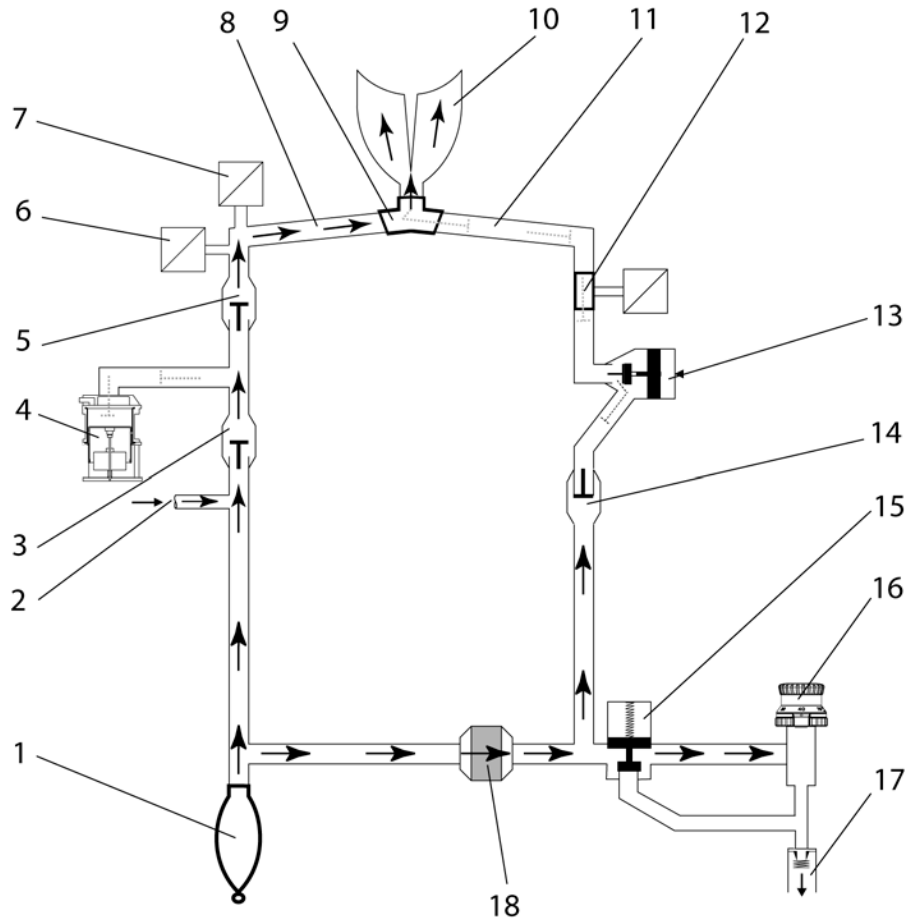

Figure 15 Functional diagram of the ventilation mode, for legend see Table 8

Table 8 Legend to Figure 15, Figure 16, Figure 17, Figure 18, Figure 19, Figure 20, Figure 21, Figure 22, Figure 23, Figure 24, Figure 25, Figure 26, Figure 27

No.	Name
1	Breathing bag
2	Fresh gas inlet
3	Fresh-gas decoupling
4	Ventilator
5	Inhalation valve
6	Pressure sensor
7	Oxygen sensor
8	Inspiratory tube
9	Y-piece
10	Lung
11	Expiratory tube

All rights reserved. Copyright reserved.  
Version 1.0\_Released\_Printed on\_10.11.05\_F5330500\_Function\_Description.fm

No.	Name
12	Flow sensor
13	PEEP/Pmax valve
14	Expiratory valve
15	APL bypass valve
16	APL valve
17	Exhaust valve
18	Absorber

## 7.2 Function description: Manual ventilation

Manual ventilation: General

During manual ventilation, the APL valve is set to the “MAN” position. The safety valve of the ventilator is activated. The piston of the ventilator is in the upper end position in order to reduce the volume of the ventilator.

The position numbers mentioned in this chapter refer to [Figure 16](#) and [Figure 17](#).

Manual ventilation: Inspiration

During inspiration, expiratory valve **14** remains closed. When the operator compresses the breathing bag **1** the gas mixture (expiratory gas and fresh gas **2**) flows through the fresh-gas decoupling valve **3**, the inspiratory valve **5**, the O<sub>2</sub> sensor **7**, the inspiratory hose **8**, and the Y-piece **9** into the patient's lung **10**. The pressure sensor **6** measures the airway pressure. The ventilation pressure is limited by the APL valve **16**. Any excess amount of the gas mixture flows through the APL valve and the non-return valve **17** to the anesthetic gas scavenging system.

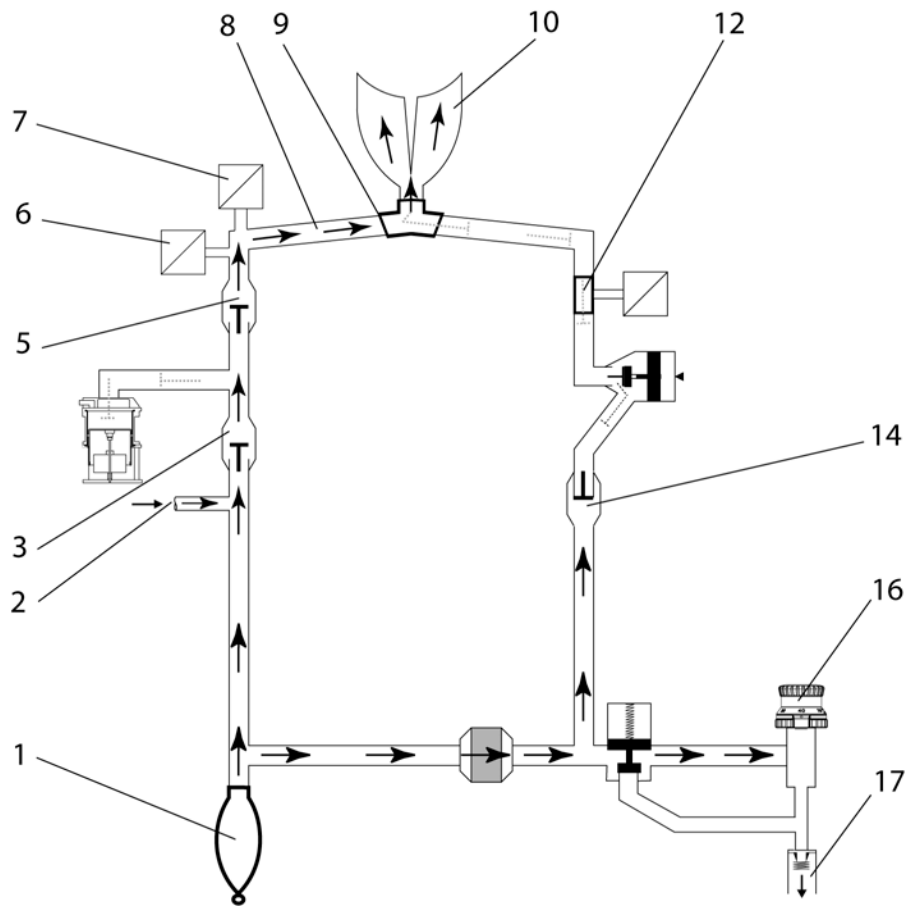

**Figure 16** Manual ventilation (inspiration) - Cosy 2 breathing system; for legend see [Table 8](#)

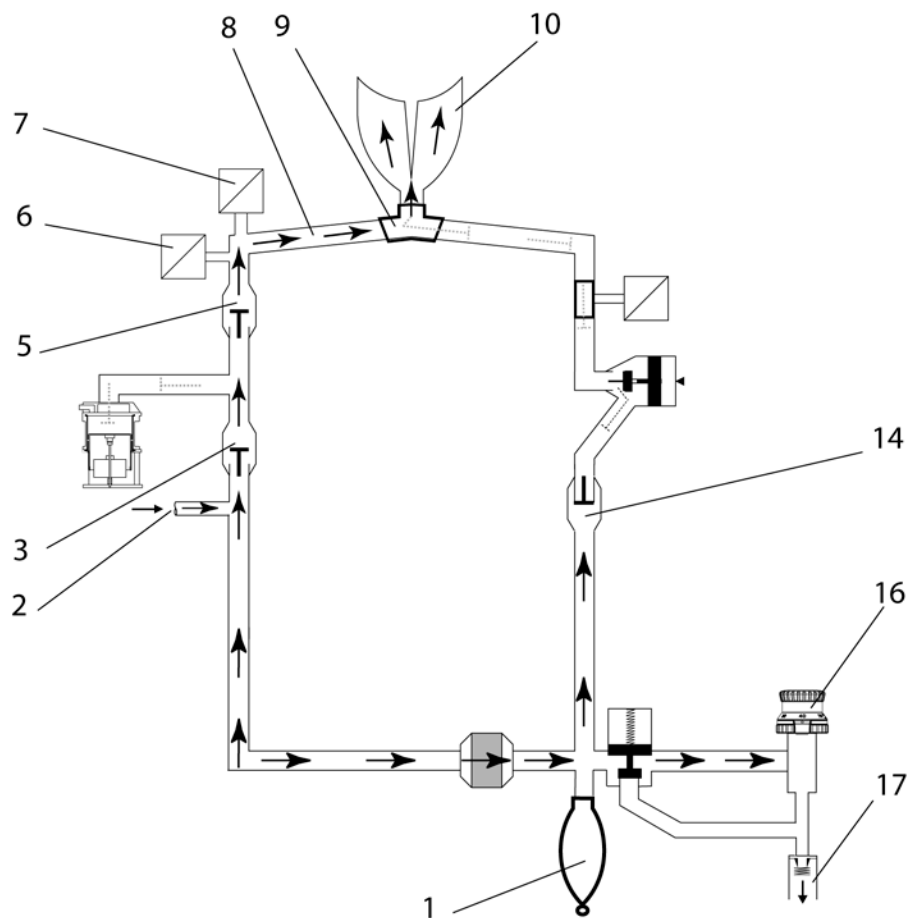

**Figure 17** Manual ventilation (inspiration) - Cosy 2.5 (2.6) breathing system; for legend see [Table 8](#)

Manual ventilation: Expiration – Cosy 2 breathing system

During expiration, the inspiratory valve remains closed thus preventing the expiratory gas from flowing back into the inspiratory branch.

The position numbers mentioned in this chapter refer to [Figure 18](#).

After releasing the breathing bag **1**, the expiratory gas from the lung **10** flows through the expiratory hose **11**, the flow sensor **12**, the PEEP/Pmax valve **13**, the expiratory valve **14**, and through the absorber **18** into the breathing bag. At the same time, new fresh gas **2** flows into the breathing bag.

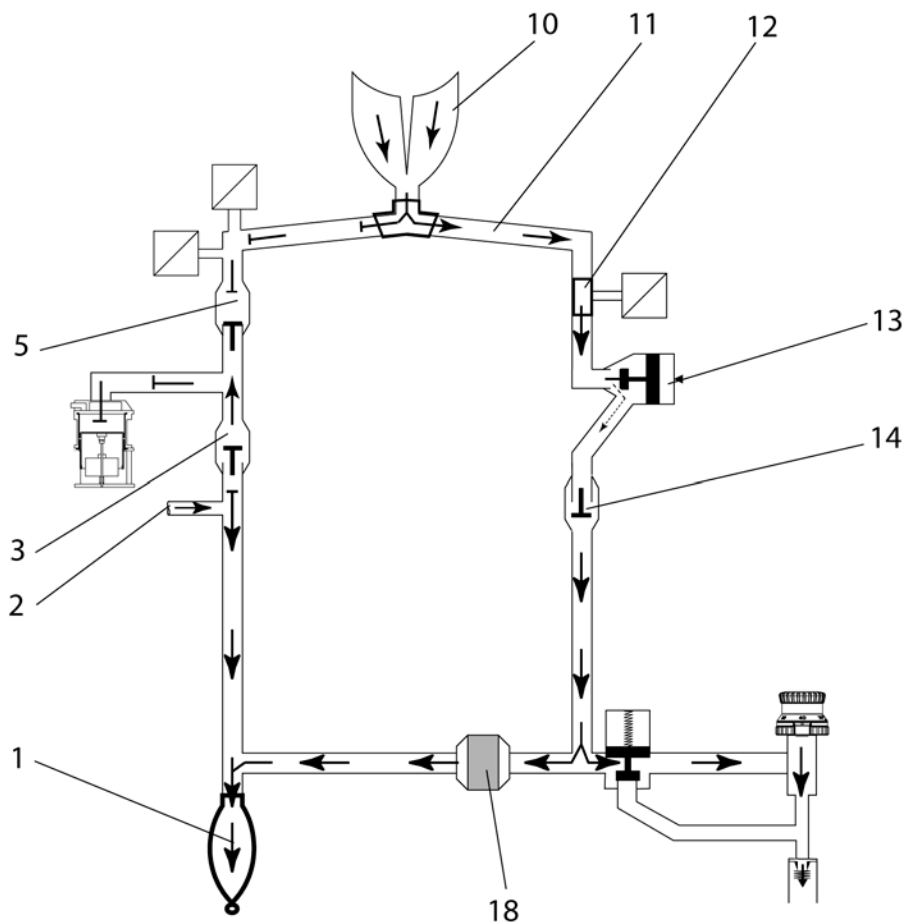

**Figure 18** Manual ventilation (expiration) - Cosy 2 breathing system; for legend see [Table 8](#)

Manual ventilation: Expiration – Cosy 2.5 (2.6) breathing system

During expiration, the inspiratory valve remains closed thus preventing the expiratory gas from flowing back into the inspiratory branch.

The position numbers mentioned in this chapter refer to [Figure 19](#).

After releasing the breathing bag **1**, the expiratory gas from the lung **10** flows through the expiratory hose **11**, the flow sensor **12**, the PEEP/Pmax valve **13**, the expiratory valve **14**, into the breathing bag and through the absorber **18**. At the same time, new fresh gas **2** flows into the breathing bag.

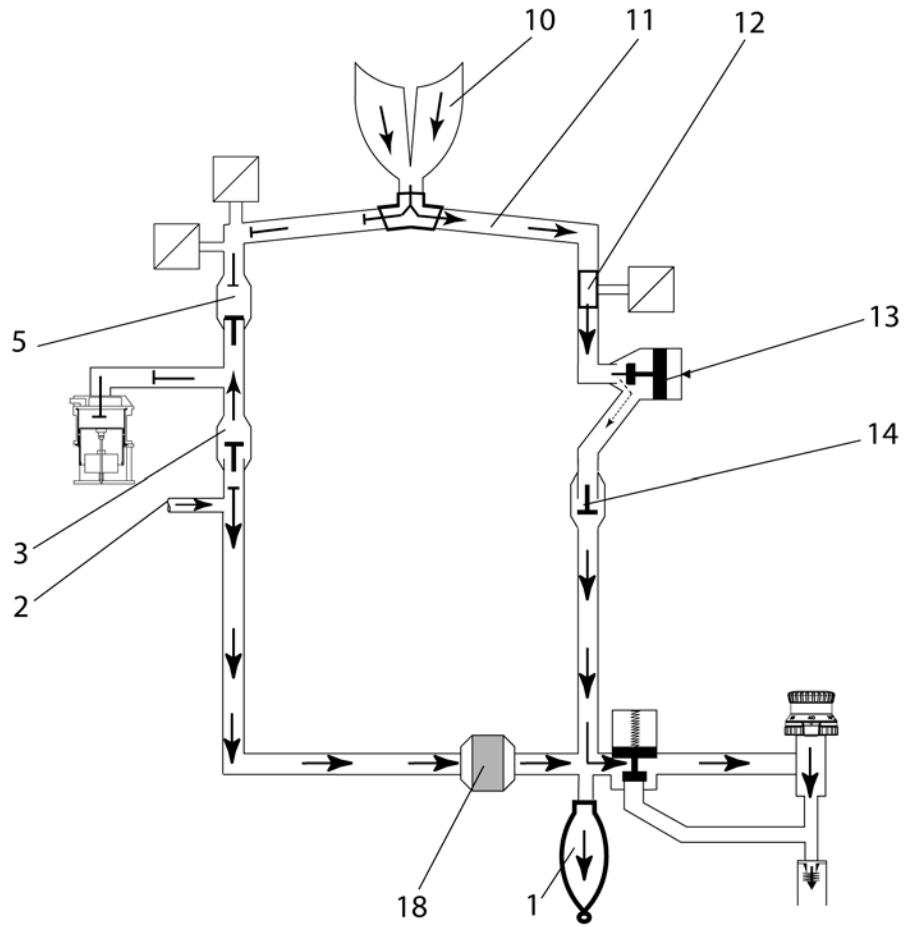

**Figure 19** Manual ventilation (expiration) - Cosy 2.5 (2.6) breathing system; for legend see [Table 8](#)

### 7.3 Function description: Spontaneous breathing

Spontaneous breathing:  
General

A prerequisite for spontaneous breathing is that the patient is supplied with a sufficient amount of fresh gas. The APL valve selector must be set to the “SPONT” position. No gas pressure builds up in the compact breathing system.

Spontaneous breathing:  
Inspiration

During inspiration, the expiratory valve remains closed thus preventing rebreathing of expiratory gas containing CO<sub>2</sub>.

The position numbers mentioned in this chapter refer to [Figure 20](#) and [Figure 21](#).

The patient inhales the gas mixture (expiratory gas and fresh gas **2**) from the breathing bag **1**. The gas mixture flows through the fresh-gas decoupling valve **3**, the inspiratory valve **5**, the O<sub>2</sub> sensor **7**, the inspiratory hose **8**, and through the Y-piece **9** into the lung **10**. The pressure sensor **6** measures the airway pressure.

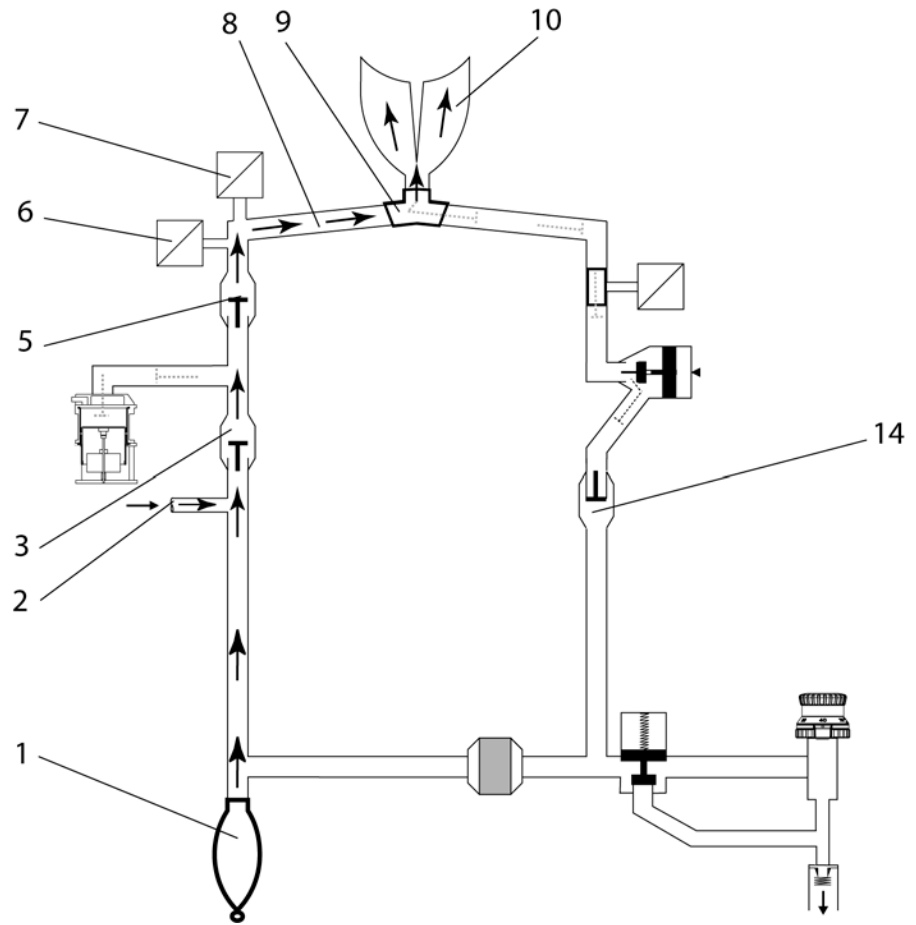

**Figure 20** Spontaneous (inspiration) - Cosy 2 breathing system; for legend see [Table 8](#)



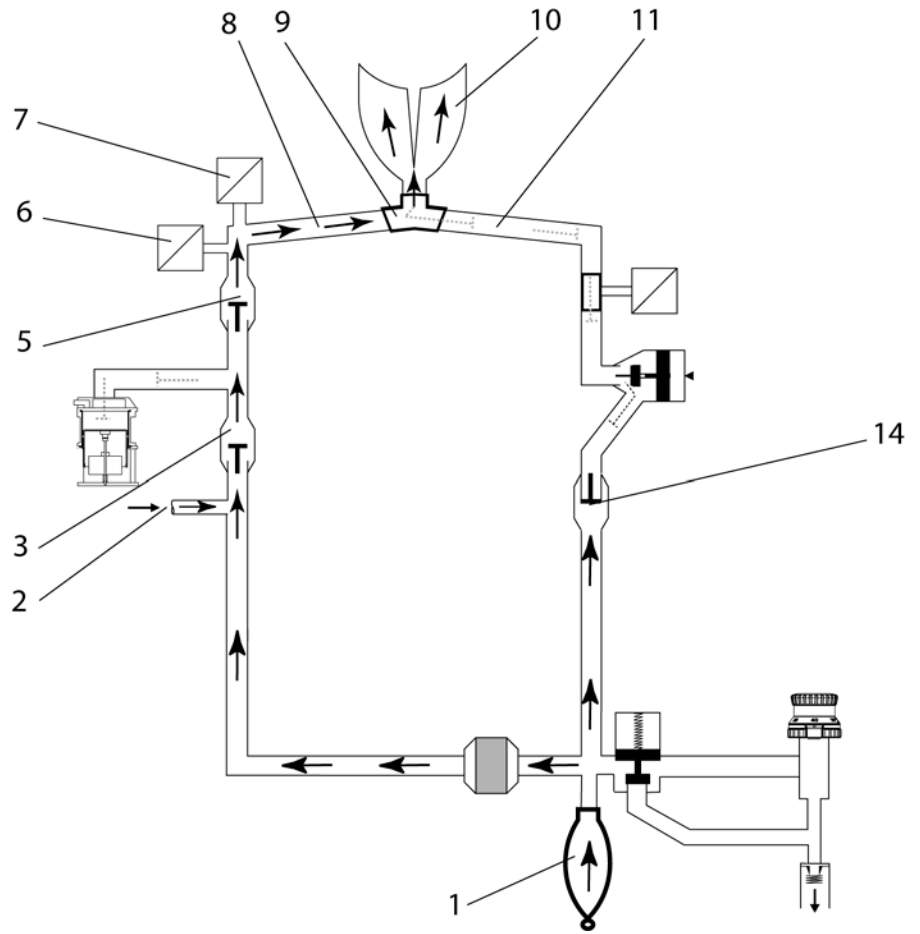

**Figure 21** Spontaneous (inspiration) - Cosy 2.5 (2.6); breathing system; for legend see [Table 8](#)

Spontaneous breathing:  
Expiration – Cosy 2  
breathing system

During expiration, the inspiratory valve remains closed thus preventing the expiratory gas from flowing back into the inspiratory branch.

The position numbers mentioned in this chapter refer to [Figure 22](#).

The APL valve **16** is open, irrespective of its pressure setting.

The expiratory gas flows from the lung **10** through the expiratory hose **11**, the flow sensor **12**, the PEEP control valve **13**, the expiratory valve **14**, and through the absorber **18** into the breathing bag **1**. At the same time, new fresh gas **2** flows into the breathing bag.

When the breathing bag is full, any excess gas mixture flows through the non-return valve **17** into the anesthetic gas scavenging system.

The CO<sub>2</sub> is scrubbed from the expiratory gas by the soda lime contained in the absorber. The fresh gas replaces the anesthetic and the oxygen taken up by the patient.

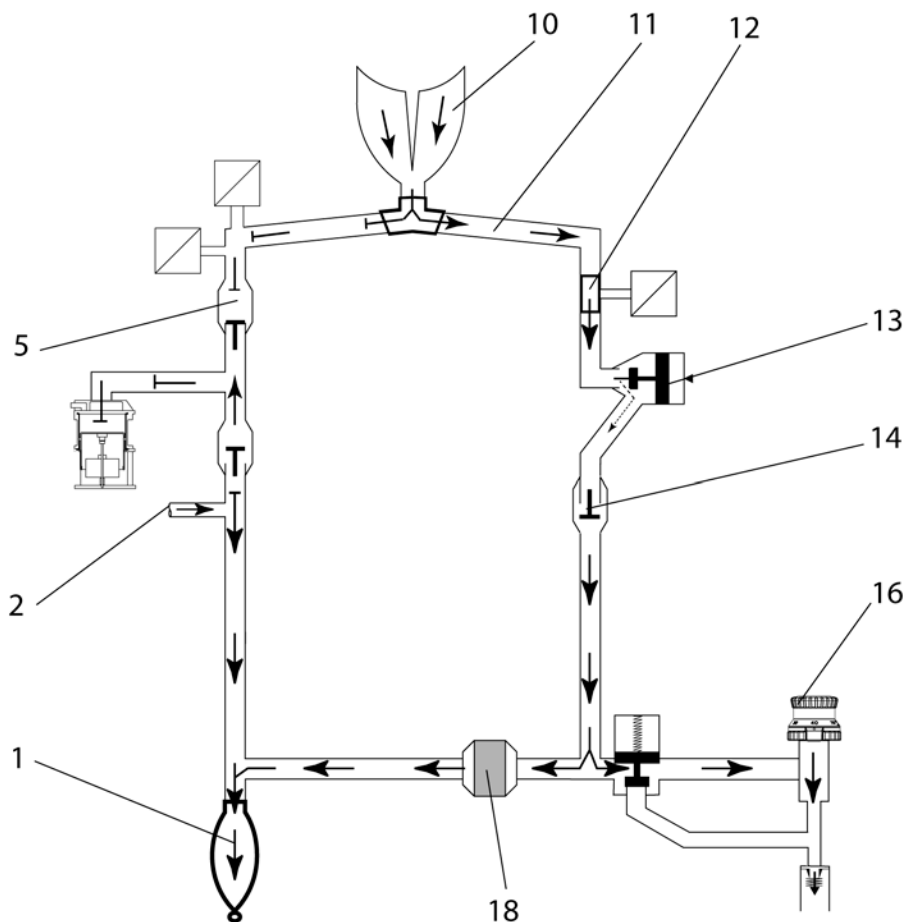

**Figure 22** Spontaneous (expiration) - Cosy 2 breathing system; for legend see [Table 8](#)

Spontaneous breathing:  
Expiration – Cosy 2.5 (2.6)  
breathing system

During expiration, the inspiratory valve remains closed thus preventing the expiratory gas from flowing back into the inspiratory branch.

The position numbers mentioned in this chapter refer to [Figure 23](#).

The APL valve **16** is open, irrespective of its pressure setting.

The expiratory gas flows from the lung **10** through the expiratory hose **11**, the flow sensor **12**, the PEEP control valve **13**, the expiratory valve **14**, the breathing bag **1** and through the absorber **18**. At the same time, new fresh gas **2** flows into the breathing bag.

When the breathing bag is full, any excess gas mixture flows through the non-return valve **17** into the anesthetic gas scavenging system.

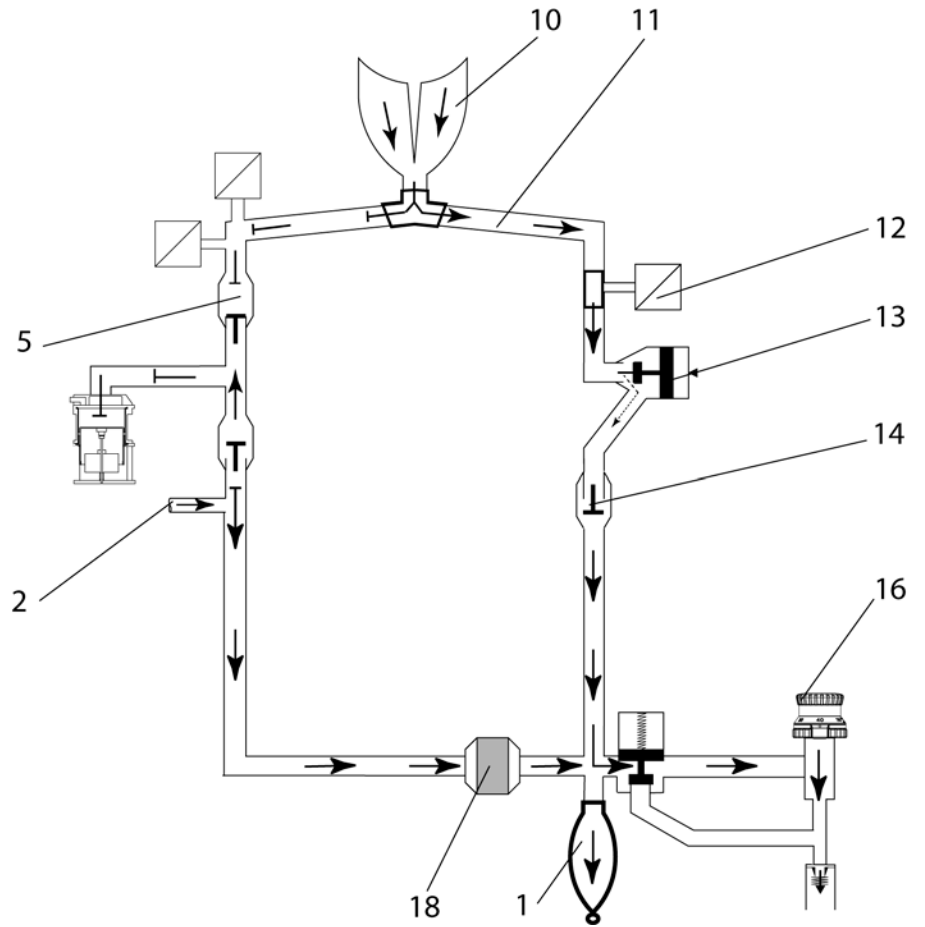

**Figure 23** Spontaneous (expiration) - Cosy 2.5 (2.6); breathing system; for legend see [Table 8](#)

**7.4 Function description: Volume/pressure control ventilation mode**

Volume control ventilation mode: General

A prerequisite for volume control ventilation is that the patient is supplied with a sufficient amount of fresh gas.

The APL bypass valve opens in volume ventilation mode, allowing excess gas to be vented to the scavenging system regardless of the MAN/SPONT valve setting.

The safety valve of the ventilator makes sure that no pressures greater than 75 cmH<sub>2</sub>O (mbar) build up in the system.

During ventilation, the pressure limit (P<sub>max</sub>) can be adjusted at the user interface.

Volume/pressure control ventilation mode: Inspiration

During inspiration, the PEEP P<sub>max</sub> valve remains closed. The control pressure present at the PEEP P<sub>max</sub> valve varies with the set pressure limit (P<sub>max</sub>).

The position numbers mentioned in this chapter refer to [Figure 24](#) and [Figure 25](#).

The pressure generated by the piston **4** of the ventilator closes the fresh-gas decoupling valve **3**. The gas mixture (expiratory gas and fresh gas **2**) flows through the inspiratory valve **5**, the O<sub>2</sub> sensor **7**, the inspiratory hose **8**, and the Y-piece **9** into the lung **10**. The pressure sensor **6** measures the airway pressure. The ventilation pressure cannot exceed the pressure limit (P<sub>max</sub>) set on the control box because the PEEP/P<sub>max</sub> valve **13** opens. The fresh gas fills the breathing bag **1**.

Any excess fresh-gas flows through the open APL valve **15**, and the non-return valve **17** into the anesthetic gas scavenging system.

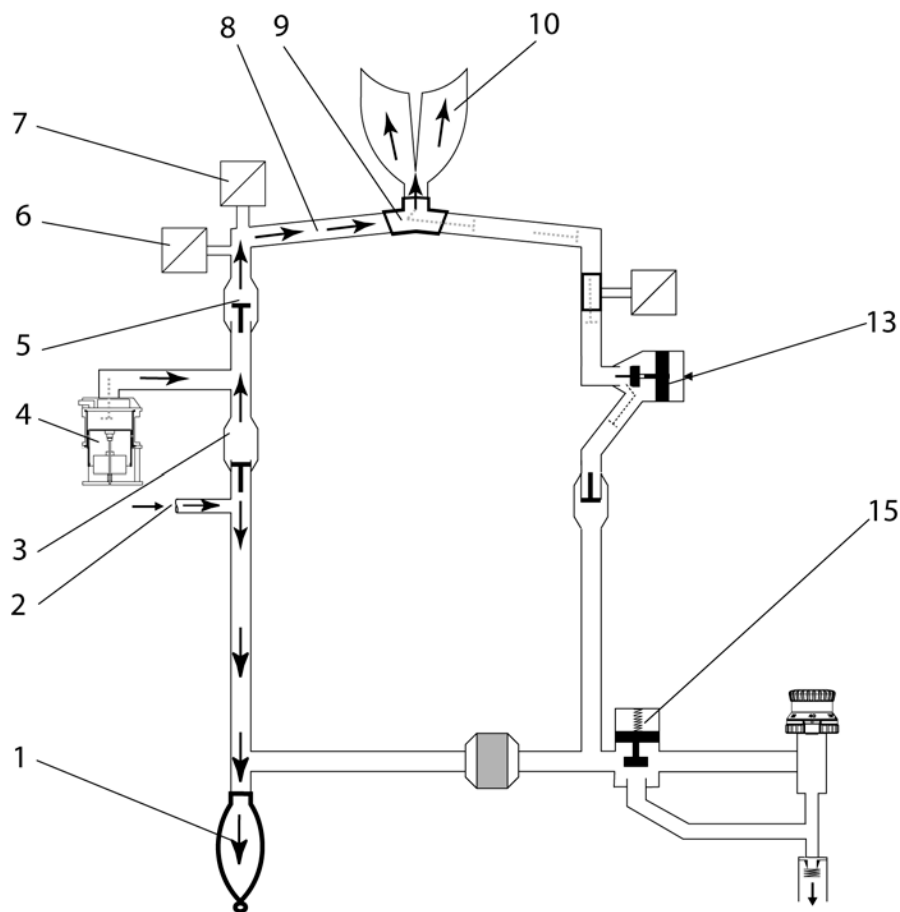

**Figure 24** Volume control ventilation (inspiration) - Cosy 2 breathing system; for legend see [Table 8](#)

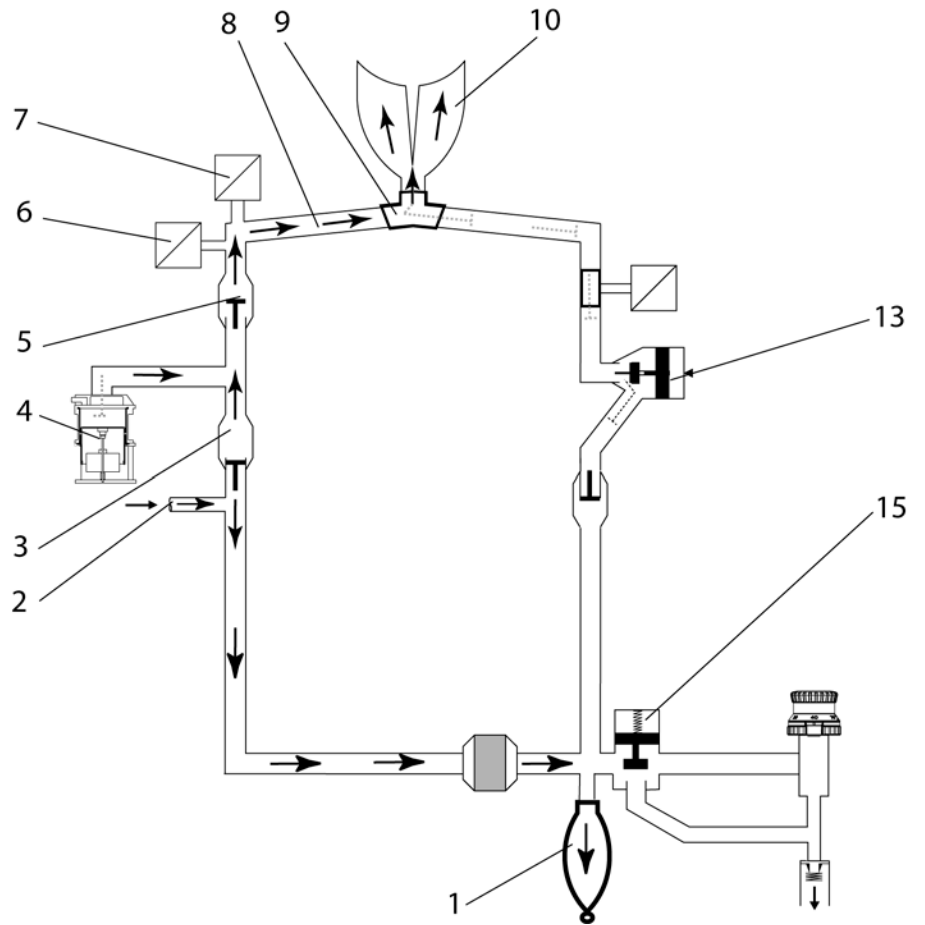

**Figure 25** Volume control ventilation (inspiration) - Cosy 2.5 (2.6); breathing system; for legend see [Table 8](#)

Volume/pressure control ventilation mode: Expiration

During expiration, the inspiratory valve remains closed thus preventing rebreathing into the inspiratory branch.

The position numbers mentioned in this chapter refer to [Figure 26](#) and [Figure 27](#).

The expiratory gas from the lung **10** flows through the expiratory hose **11**, the flow sensor **12**, the PEEP/Pmax valve **13**, the expiratory valve **14**, and the absorber **18** back into the breathing bag **1** mixing with fresh gas **2** also flowing into the breathing bag.

The ventilator's piston **4** moves back drawing the gas mixture needed for the next inspiration into the piston space.

Any excess fresh-gas flows through the open APL valve **15**, and the non-return valve **17** into the anesthetic gas scavenging system.

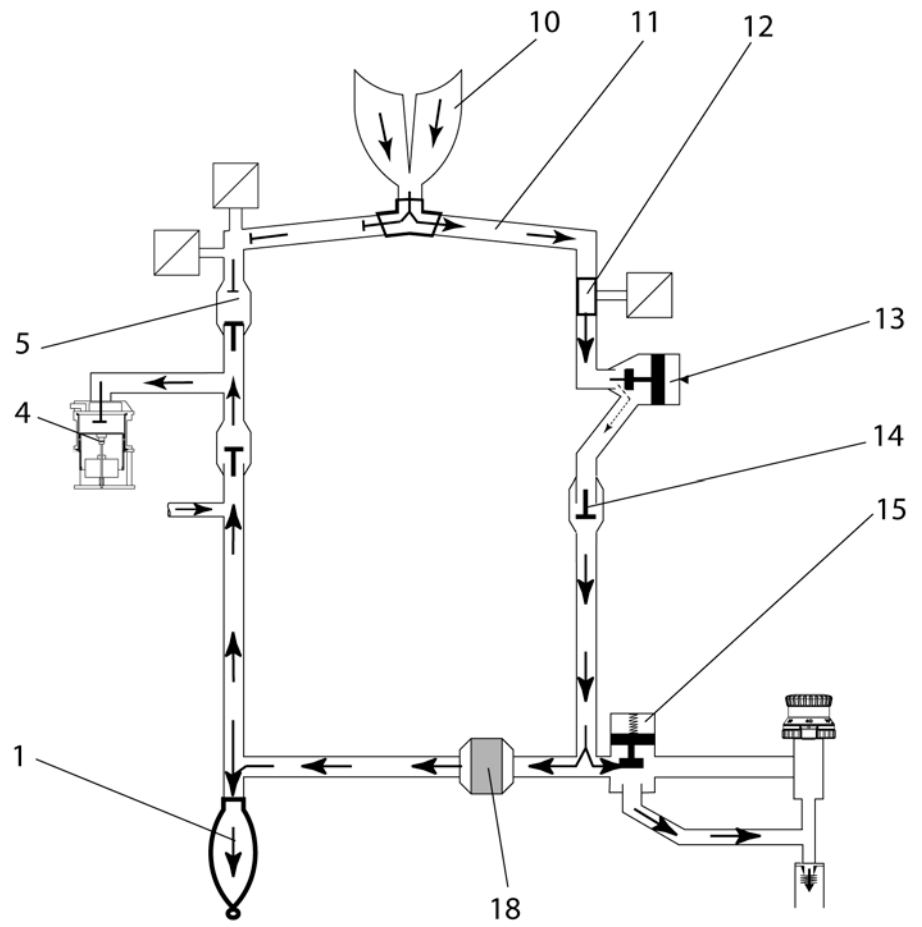

**Figure 26** Volume control ventilation (expiration) - Cosy 2 breathing system; for legend see [Table 8](#)

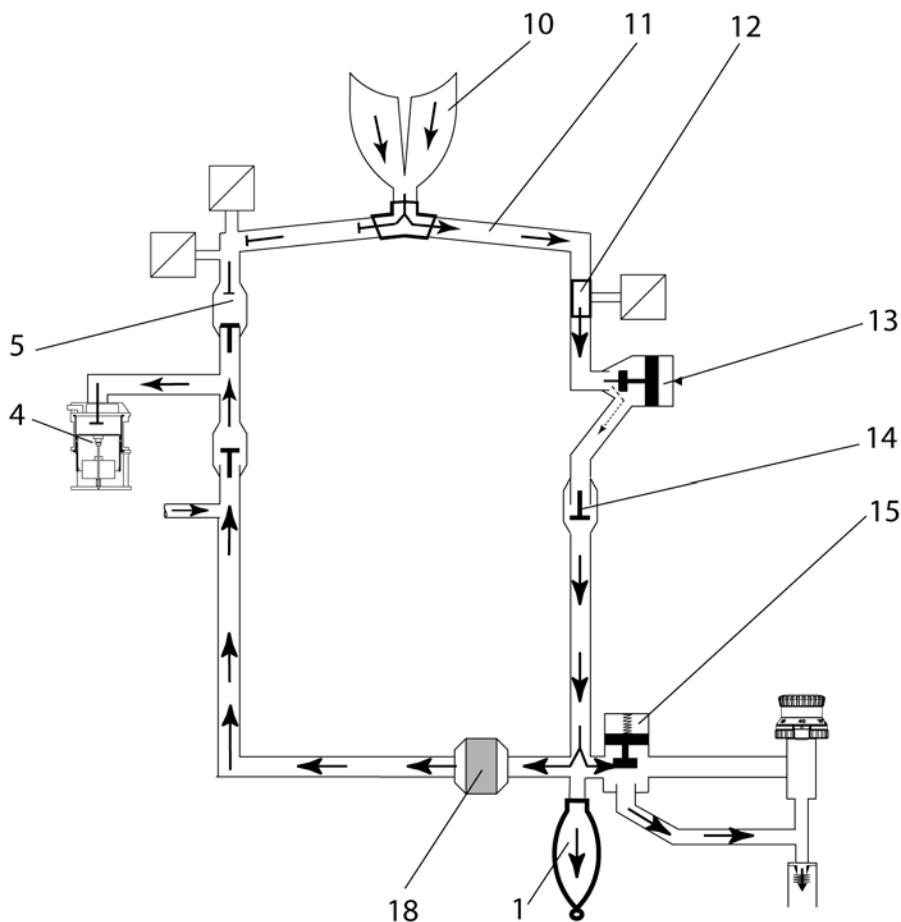

**Figure 27** Volume control ventilation (expiration) - Cosy 2.5 (2.6); breathing system; for legend see [Table 8](#)

**7.5 Cosy 2 absorber**

The absorber canister is filled with fresh soda lime. The CO<sub>2</sub> is scrubbed from the expiratory gas by the soda lime.

Expired soda lime changes its color. The soda lime must be replaced when two thirds of the soda lime in the absorber canister is discolored.

**8 Ventilator**

The ventilator is located in a swing-out compartment at the left side of the Fabius GS. The ventilator is connected to the Cosy 2 via a tube. Fresh gas is delivered to the patient by a piston that is driven by a motor and ball-screw arrangement. A sight window on the compartment allows the operator to verify movement of the piston.

Two diaphragms (upper and lower) form a bag-type rolling seal that surrounds the piston. The pneumatic assembly generates a vacuum between the seal and the cylinder, to ensure proper operation of the upper seal during piston movement.

During inspiration the ventilator delivers fresh gas at a given volume, pressure and frequency. These parameters are set at the control panel. Refer to the Operator's Manual for details on ventilator settings, displays and controls. During expiration, the bag-type rolling seal fills with expired gas from the patient and with fresh gas stored in the breathing bag.

The ventilator motor is controlled by the Control PCB. A light barrier on the ventilator signals the Control PCB when the piston reaches its lower limit. An incremental encoder on the motor shaft determines the number of revolutions and provides piston travel information to the control PCB.

The ventilator pressure is monitored by a Paw pressure sensor on the Control PCB. When the auxiliary air valve on the patient system opens, a fresh-gas low alarm is generated if it has been enabled in the service mode.

The ventilator pressure sensor is the same type as the one used for measuring airway pressure. The ventilator pressure is picked up at the ventilator cover. This sensor allows the software to detect a fresh-gas low situation. The threshold value used by the software for this condition is listed in the table below. In normal use the primary cause for this condition is an insufficient amount of reserve gas in the breathing bag. The operator is alerted when this condition exists, with a medium priority "FRESH GAS LOW" alarm. This alarm can be disabled in service mode.

**Table 9      Threshold**

Software version	Threshold
US units with SW >1.20	-8 mbar (cmH20)
US units with SW 1.20	-3 mbar (cmH20)
Non-US units with SW ≤1.20	-3 mbar (cmH20)
Non-US units with >SW 1.20	-8 mbar (cmH20)



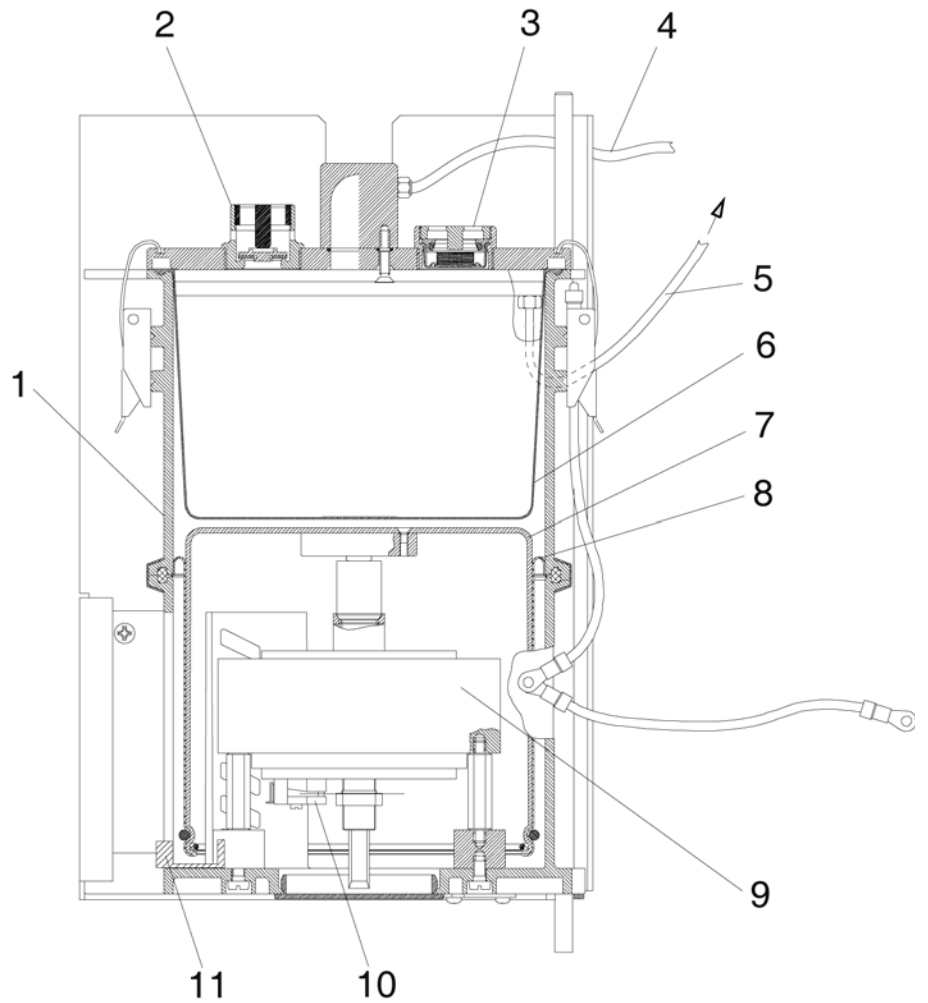

**Figure 28** Ventilator (piston shown in 'down' position), for legend see [Table 10](#)

**Table 10** Legend to [Figure 28](#)

No.	Name
1	Cylinder
2	Safety valve
3	Auxiliary air valve
4	Ventilator pressure sensor line
5	Vacuum line to the pneumatic assembly
6	Upper diaphragm
7	Piston
8	Lower diaphragm
9	Motor/ballscrew assembly
10	Incremental encoder
11	Light barrier

The top of the ventilator assembly (patient system) contains two valves:

### 8.1 Safety valve

If the pressure limit control fails, the ventilator's safety valve limits the gas pressure. This valve is set to open at approximately 75 cmH<sub>2</sub>O (mbar).

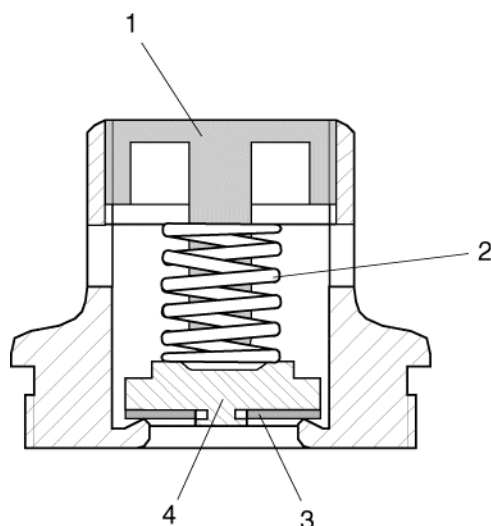

Figure 29 Sectional view of the safety valve, for legend see Table 11

Table 11 Legend to Figure 29

No.	Name
1	Screw
2	Spring
3	Washer
4	Valve disc

### 8.2 Auxiliary air valve

The auxiliary air valve allows the patient to spontaneously breathe ambient air should the medical gas supply and/or Fabius GS fail. The opening pressure of this valve is listed in the table below.

Table 12 Threshold

Software version	Threshold
US units with SW >1.20	-8 mbar (cmH <sub>2</sub> O)
US units with SW 1.20	-3 mbar (cmH <sub>2</sub> O)
Non-US units with SW ≤1.20	-3 mbar (cmH <sub>2</sub> O)
Non-US units with >SW 1.20	-8 mbar (cmH <sub>2</sub> O)

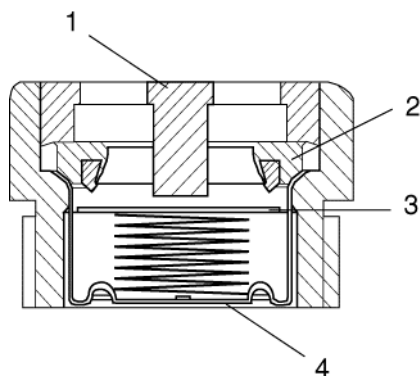

**Figure 30** Sectional view of the auxiliary air valve, for legend see [Table 13](#)

**Table 13** Legend to [Figure 30](#)

No.	Name
1	Threaded ring
2	Valve seat
3	Valve disc
4	Valve cross with spring

**9 Pneumatics**

The pneumatic assembly provides pressure for the PEEP valve control, and also provides vacuum for the ventilator bag-type rolling seals and the APL bypass valve control.

**9.1 PEEP/Pmax valve control**

When the Fabius GS is operating in the automatic mode, the pump on the pneumatic assembly is running, and the electronic PEEP valve is actuated by the Control PCB. The current supplied to the coil of the electronic PEEP valve is proportional to the set PEEP value, and controls the position of the diaphragm within the electronic PEEP valve. This then determines the control pressure applied to the proportional PEEP valve in the breathing system, which maintains the desired amount of PEEP during patient expiration. The V1 reservoir smooths out pressure variations caused by the pump. See [Figure 31](#).

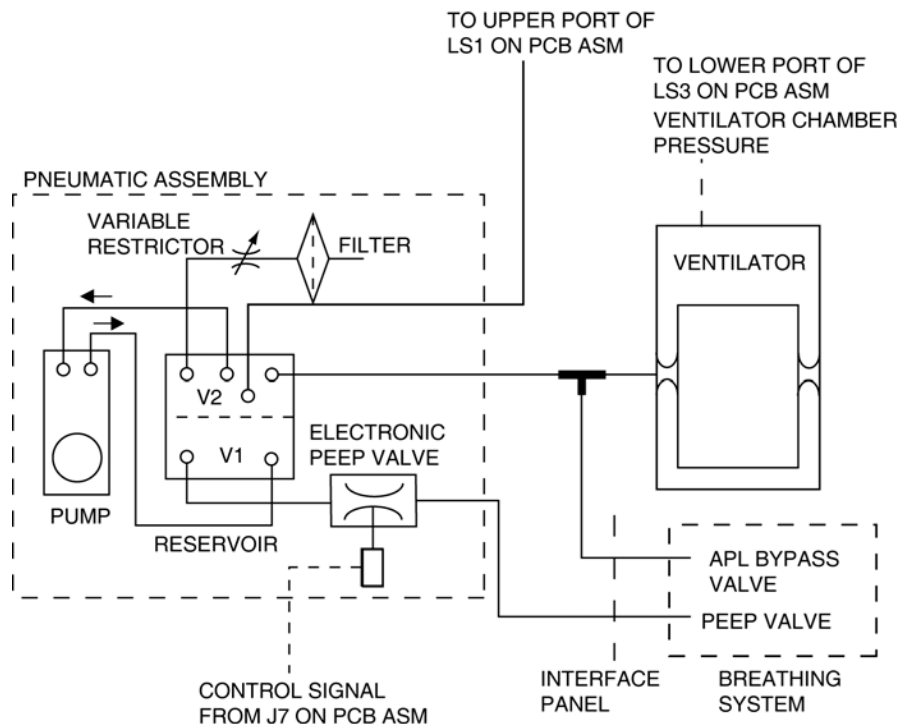

Figure 31 Pneumatic control system schematic

## 9.2 APL bypass valve control

When the Fabius GS is operating in the automatic mode, the pneumatic assembly provides a vacuum signal to hold open the APL bypass valve in the breathing system. The V2 reservoir and filter provide noise damping, and the variable restrictor is used to set the vacuum level in the range of  $-150$  to  $-240$  cmH<sub>2</sub>O (mbar).

When the machine is operating in the Manual mode, the pump on the pneumatic assembly (and the ventilator) is stopped, and the spring-loaded APL bypass valve in the breathing system closes, directing exhaled gas through the APL valve.

10 Electrical block diagram

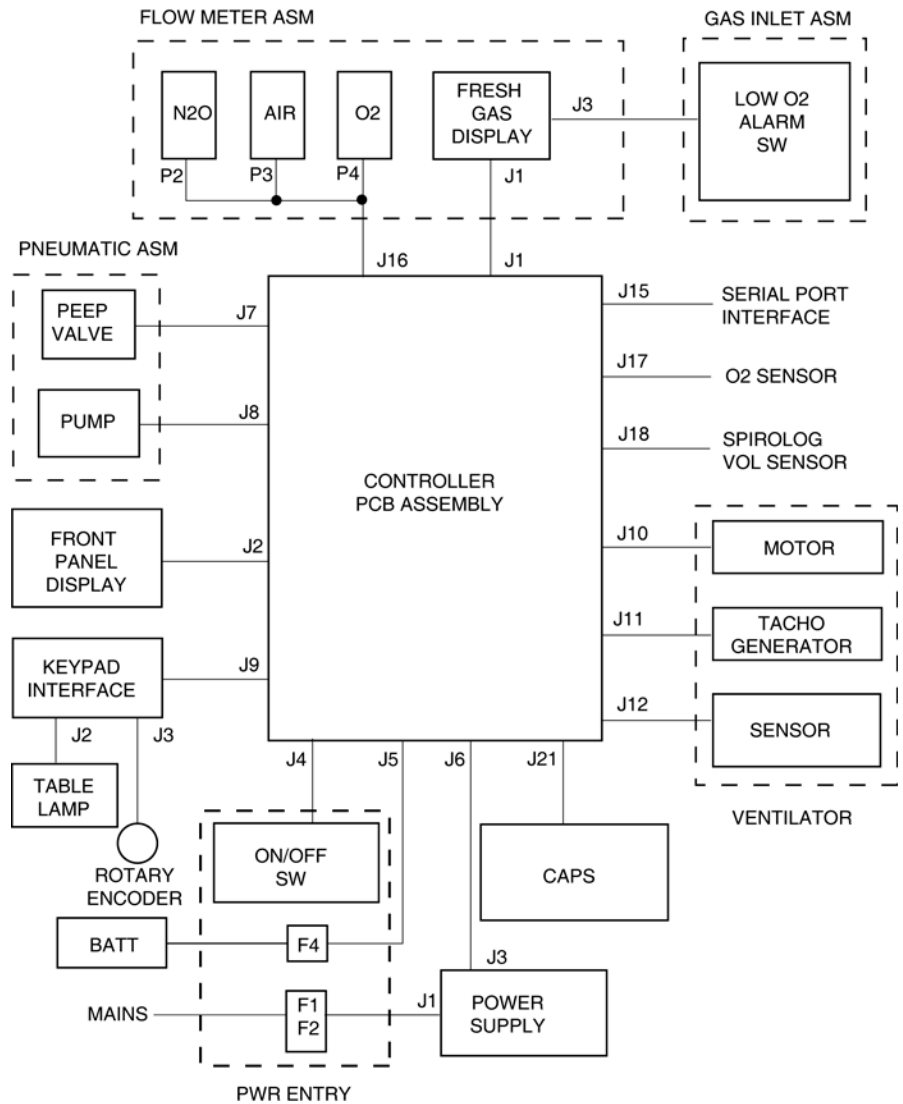

Figure 32 Electrical block diagram

11 Function description: Control PCB

The Control PCB contains the following functions:

- Motor control and monitoring
- Measurement of O2 and flow parameters
- Provision of one or two serial interfaces
- Evaluation of the O2 low signal
- Measurement and display of fresh-gas parameters
- PEEP valve control
- Pump control
- Front panel display control
- Evaluation of keypad and rotary encoder
- The required supply voltages are supplied by the power supply unit.

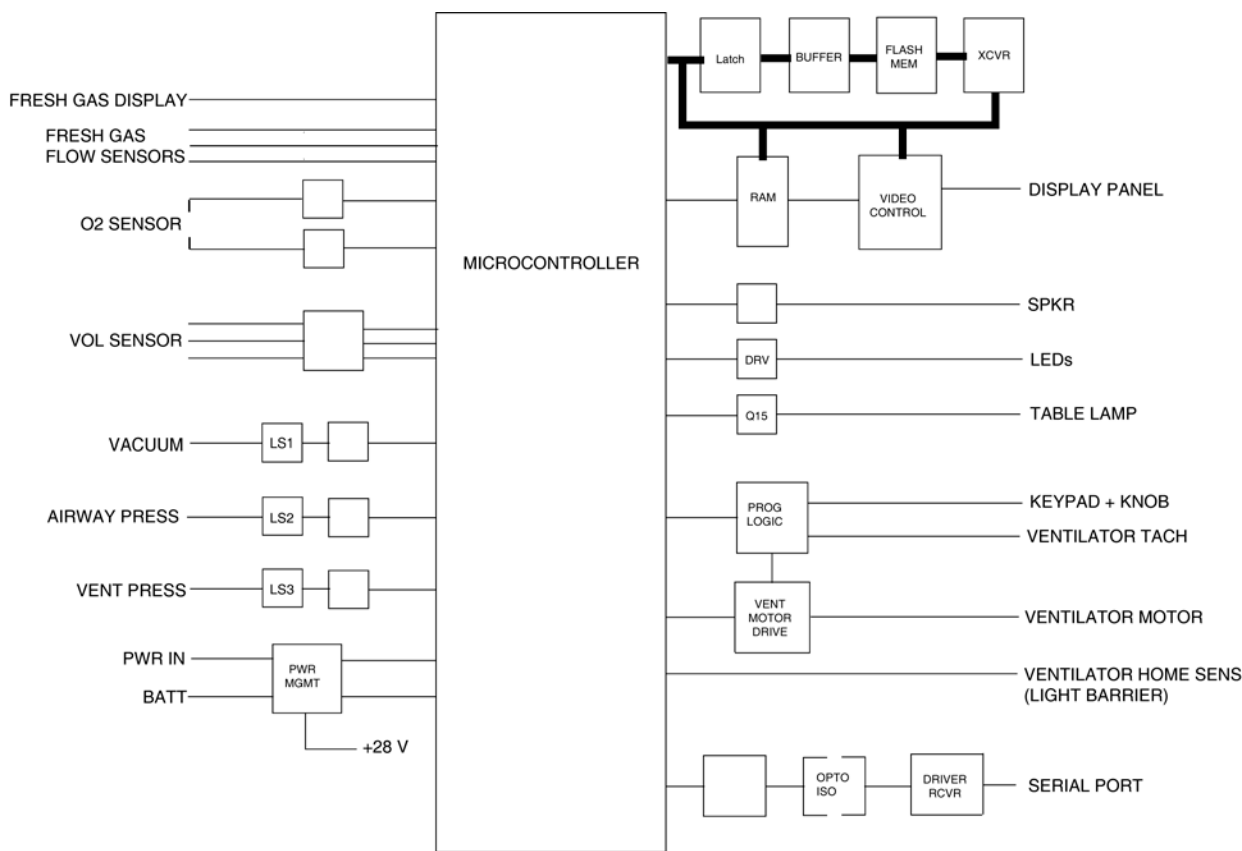

Figure 33 Controller functional block diagram

## 12 Control panel assembly

The control panel consists of a 320 x 240 pixel graphical display, a table lamp with six LEDs, a membrane keypad, rotary encoder and speaker.

Data and power for the display comes from the Control PCB via a 20-conductor ribbon cable. The keypad interface is connected to the Control PCB by a 30-conductor ribbon cable. A block diagram of the control panel assembly is shown in the following illustration.

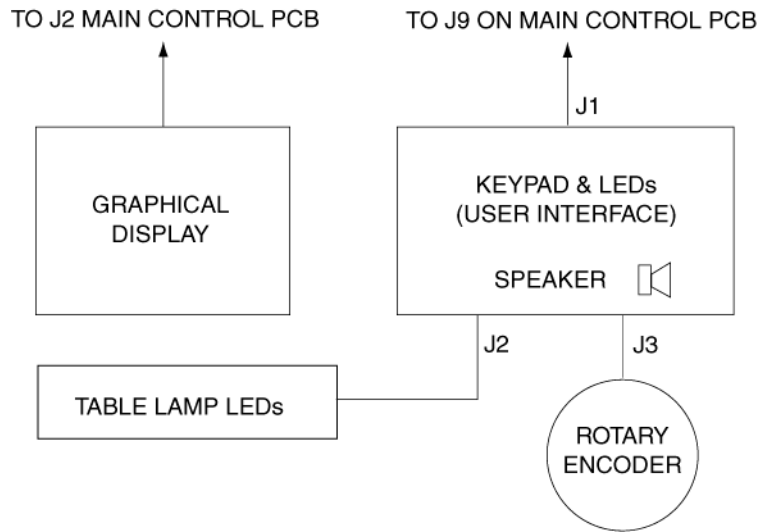

Figure 34 Control panel block diagram

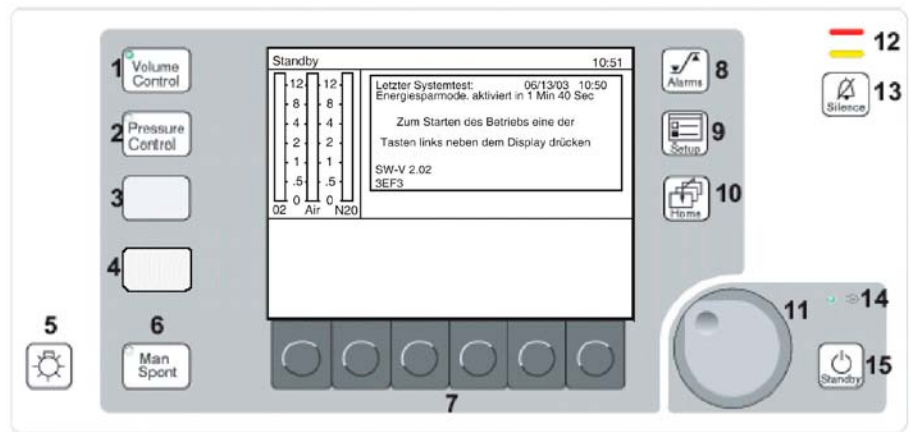

Figure 35 Fabius GS control panel (“Standby” screen shown), for legend see Table 14

Table 14 Legend to Figure 35

Item	Function
1	Selects volume control ventilation mode. Refer to Instructions for Use manual
2	Selects pressure control ventilation mode. Refer to Instructions for Use manual
3	Reserved for future functions (Pressure Support)
4	Reserved for future functions (SIMV)
5	Controls table lamp: Off/On
6	Places the ventilator in MAN/SPONT mode Refer to Instructions for Use manual

Item	Function
7	Soft keys: activate the corresponding function that appears on screen above the key
8	For setting alarm limits Refer to Instructions for Use manual
9	Setup key: activates sub-screens for monitoring functions. Refer to Instructions for Use manual
10	Home key: returns display to main screen shown before standby
11	Rotary encoder: moves the cursor on the screen; confirms selection when pressed
12	Alarm Status indicators: Flashing Red: Warning; Flashing Yellow: Caution; Solid Yellow: Note
13	Alarm Silence key: silences all active alarms for two minutes
14	Power ON indicator: lighted when machine is plugged into an active AC outlet
15	Switches the unit back to standby mode.

### 13 FiO2 Measurement

The O2 sensor measures the O2 concentration in the respiratory gas (FiO2).

The O2 sensor contains a capsule with alkaline electrolyte, a lead anode, two gold cathodes, and a Teflon membrane. The spatial separation of the two gold cathodes allows to carry out a voltage comparison.

The O2 sensor is an electrochemical cell that generates a voltage from the ion current.

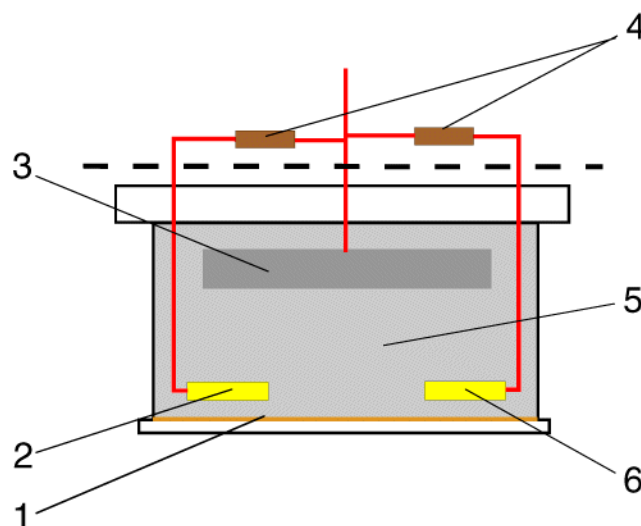

Figure 36 O2 sensor, for legend see Table 15



**Table 15** Legend to [Figure 36](#)

No.	Name
1	Teflon membrane
2	Gold cathode A
3	Lead anode
4	Temperature compensation resistors
5	Alkaline electrolyte
6	Gold cathode B

The O<sub>2</sub> to be measured diffuses through the Teflon membrane, undergoes a chemical reaction at the gold cathodes (negative) and produces lead oxide and water at the lead anode (positive). During this chemical process, a voltage is generated that is proportional to the O<sub>2</sub> partial pressure.

The internal resistance of the cell is determined by the surface of the gold cathodes, the O<sub>2</sub> diffusion velocity, and the distance between the gold cathodes and the lead anode. This resistance is approximately 700 ohms.

The chemical process is temperature-sensitive. Therefore, thermistors are connected in parallel to the O<sub>2</sub> sensor. These resistors and the internal resistor of the O<sub>2</sub> sensor correct the measuring voltage. Since two cathodes are used in the O<sub>2</sub> sensor cell, two different voltages are generated. These voltages are compared with each other. If their difference exceeds a certain value, the machine prompts the operator to check the cell.

If the O<sub>2</sub> sensor fails, the control box will indicate an error on the graphics display.

## 14 Respiratory Flow Measurement

The flow sensor functions according to the constant temperature hot-wire anemometer principle. Respiratory gas flows past a thin platinum wire. This platinum wire (A) is located in a measuring tube and is electrically heated. The platinum wire is held at a constant temperature. Gas flow removes heat from the hot wire. The higher the gas flow rate, the greater the heat removal. The amount of electrical current needed to maintain a constant platinum wire temperature is thus proportional to the gas flow rate.

A second platinum wire (B) in the measuring tube is used to compensate for interferences from different gases present in the respiratory gas. The heat removed from the second platinum wire is measured during inspiration when the gas flow is zero.

The different gases present in the respiratory gas have a different thermal conductivity. The amount of heat removed from the second platinum wire is thus an indicator of respiratory gas composition.

Internal calibration tables for O<sub>2</sub>/N<sub>2</sub>O mixtures, Air and 100% O<sub>2</sub> are used to linearize the measured flow.

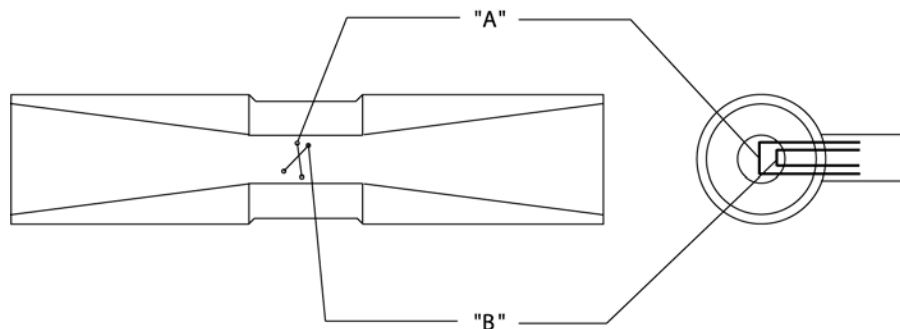

Figure 37 Respiratory flow sensor, for legend see Table 16

Table 16 Legend to Figure 37

No.	Name
"A"	Platinum wire "A"
"B"	Platinum wire "B"

15 Gas flow rate measurement

The gas flow sensors operate on the principle of specific heat for individual gases. In each sensor, as the gas flows through a heated chamber the gas molecules carry away a certain amount of heat relative to the specific heat index for that gas.

A known amount of electrical current is required to maintain the temperature in the heated chamber. The higher the gas flow rate, the more heat is removed from the chamber and more current is required to maintain the temperature in the chamber. This current is then scaled and displayed as liters per minute flow rate for each gas.

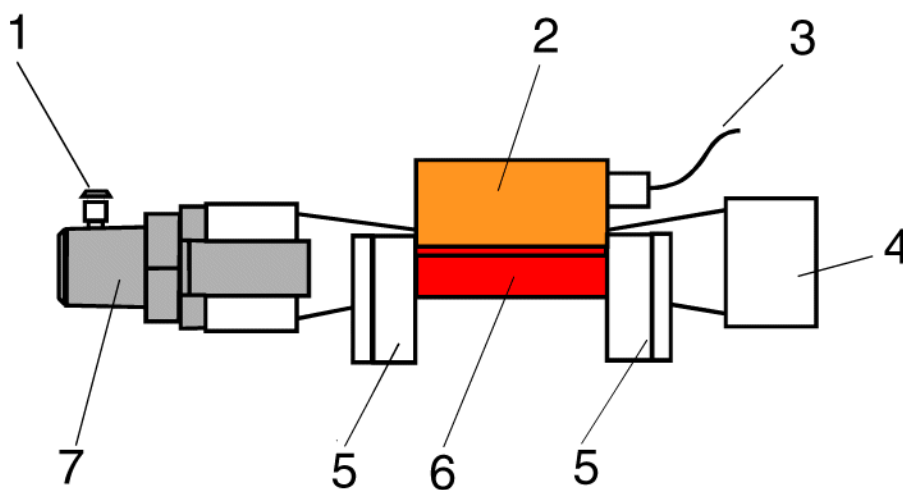

Figure 38 Details of the flow sensor, for legend see Table 17

Table 17 Legend to Figure 38

No.	Name
1	Tube connector
2	Electronic components
3	Electrical connection
4	Gas outlet port (to manifold)
5	Mounting pole
6	Heated chamber
7	Gas inlet assembly

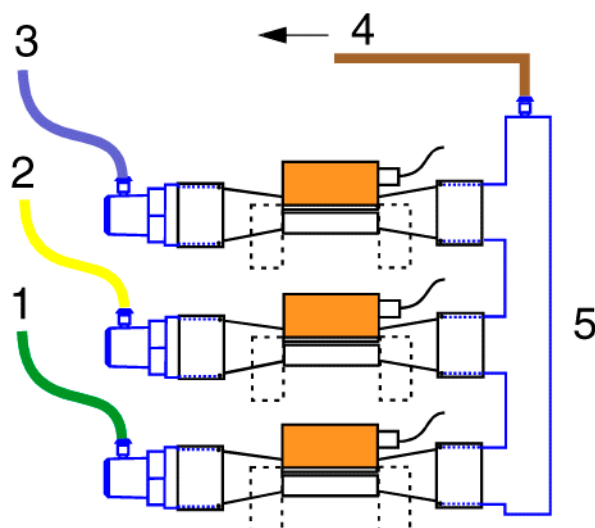

Figure 39 Gas flow through sensors, for legend see Table 18

Table 18 Legend to Figure 39

No.	Name
1	from the oxygen flow control valve
2	from the Air flow control valve
3	from the N2O flow control valve
4	Fresh-gas flow to the total fresh-gas flowmeter
5	Fresh-gas manifold

**16 Anesthetic vaporizer(s)**

Refer to separate technical documentation of the anesthetic vaporizer.



## 17 Leak test

The leak test menu screen instructs the user how to begin the leak test.

After preparing the machine, the user initiates the test.

If the size of the leak is outside the tolerance range, an appropriate message is displayed to tell the user that the system leak test has failed.

With sidestream monitoring, seal off the sampling tube from the Y-piece, otherwise there will be an additional leak rate of 150 to 200 mL/min.

### 17.1 System leak test

1. The leak test menu prompts the user to plug the Y-piece and to flip the Man/Spont valve to "Man" (with the pressure set to 40 to 50 mbar).
2. The motor control then moves the piston upward. Then the user activates the O<sub>2</sub> flush to increase the system pressure to a value between 15 and 30 mbar.
3. The software monitors the airway pressure.
4. If the airway pressure is in range, the airway pressure is then allowed to drop for 15 seconds or by 1.5 mbar. If no appreciable pressure drop occurred in 15 seconds, the leak test is considered "passed".
5. If the pressure has decreased significantly (up to 1.5 mbar), the piston will move upward until the airway pressure has increased 2 mbar, or the piston has moved upward a specific volume of 160 mL, whichever comes first.
6. The upward piston movement in mL, divided by the increase in airway pressure yields the system compliance value. This compliance value is used when calculating the system leak rate only. The system compliance is calculated in the next step upon completion of the system leak test.
7. The total time that elapsed between the start of the piston movement and the transition pressure drop by 1.5 mbar is the time base for the leak calculation.

### 17.2 Patient leak test

The patient leak test is done in a similar way to the system leak test:

1. The PEEP/Pmax valve is used to close off the expiratory part of the pneumatic circuit. Only the patient circuit is tested.
2. The test begins by opening the PEEP valve and checking where the current piston position is.
3. If the piston is above the desired starting position the piston is servoed downward.
4. If the piston is below the desired starting position the piston is servoed upward.
5. Then the PEEP valve is closed and the piston is moved upward.
6. When the airway pressure has reached 30 mbar, the piston is paused at that position and maintained there by the servo function.
7. Once the pressure has stabilized, the state changes to "waiting for leak."
8. When the airway pressure and ventilator pressure have dropped 1 mbar or the elapsed waiting time exceeds 20 seconds, the state changes to calculation of the leak in mL and leak rate in mL/min.
9. The software detects that the completion state has gone to "pass" or "fail" and will then display the leak test results on the leak test screen (or display an appropriate error message, if the completion state is one of the error conditions).

The result of the “patient leak test” is displayed after each test.  
The result of the “system leak test” is displayed only if the value is outside the tolerance range.  
Otherwise only OK will be displayed.

# **Annex**

**Parts catalog**

**Technical Information**





# Parts catalog

Fabius GS



Revision: 2005-09

5330.500



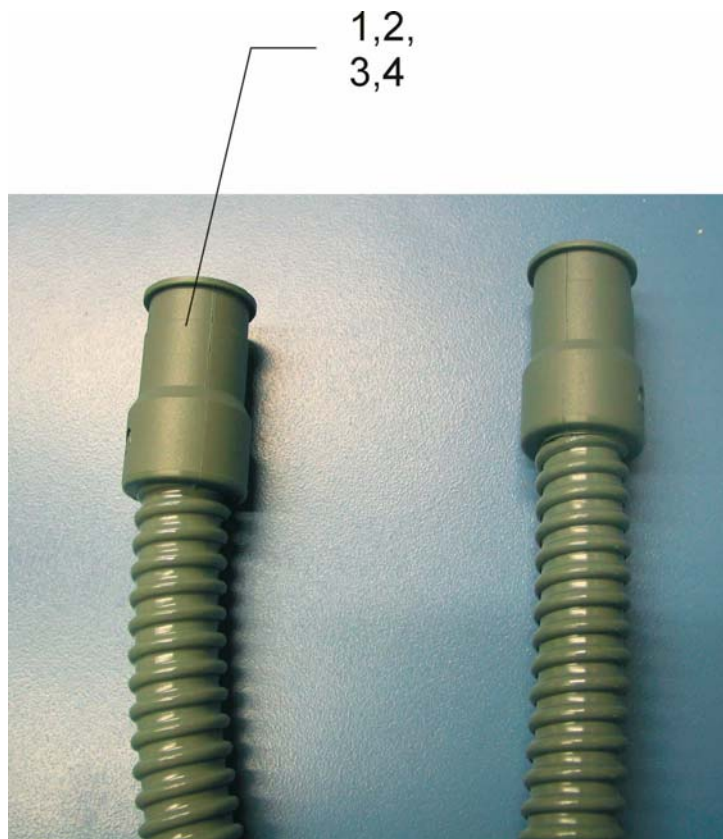

Item No.	Part No.	Description	Qty.	Qty. unit	Remark
1	M35015	AGS-SCAVANGER HOSE 0,5M	1.000	St	
2	M33297	AGS-SCAVANGER HOSE 1,5M	1.000	St	
3	M33298	AGS-SCAVANGER HOSE 3M	1.000	St	
4	M33299	AGS-SCAVANGER HOSE 5M	1.000	St	

Items that are shown in the illustration but are not listed below the illustration are not available as spare parts

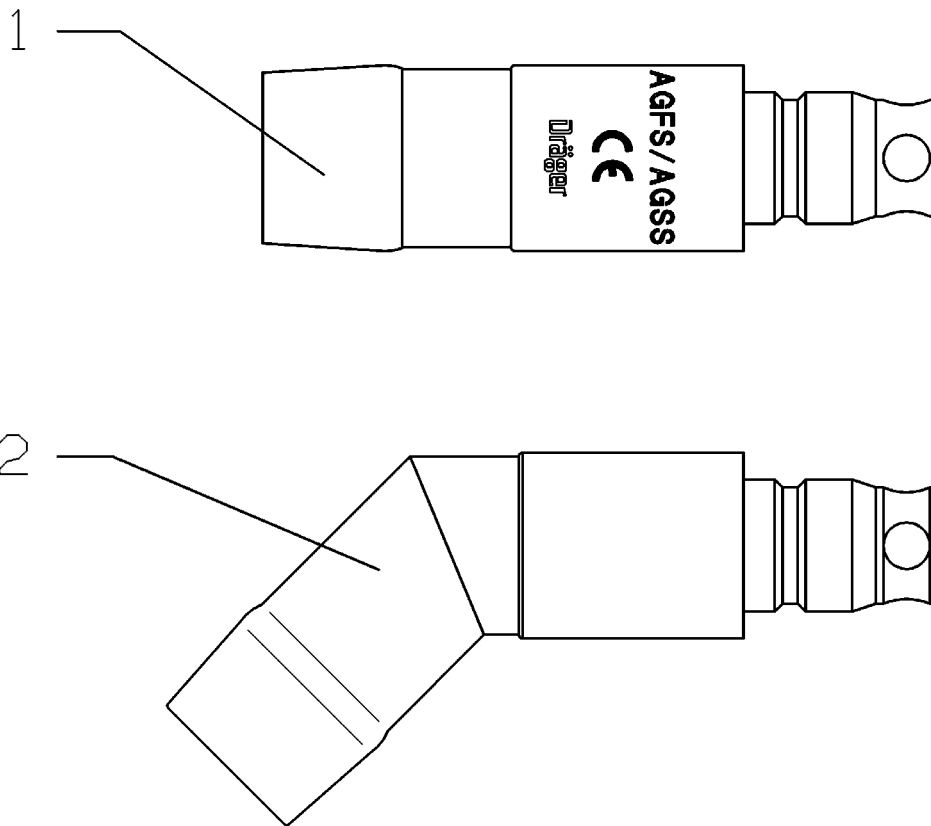

Item No.	Part No.	Description	Qty.	Qty.u nit	Remark
1	G60580	AGSS PROBE/STRAIGHT-TYPE1/ EN	1.000	St	
2	G60495	AGSS ANGLE PROBE / TYPE 1 / EN	1.000	St	

Items that are shown in the illustration but are not listed below the illustration are not available as spare parts

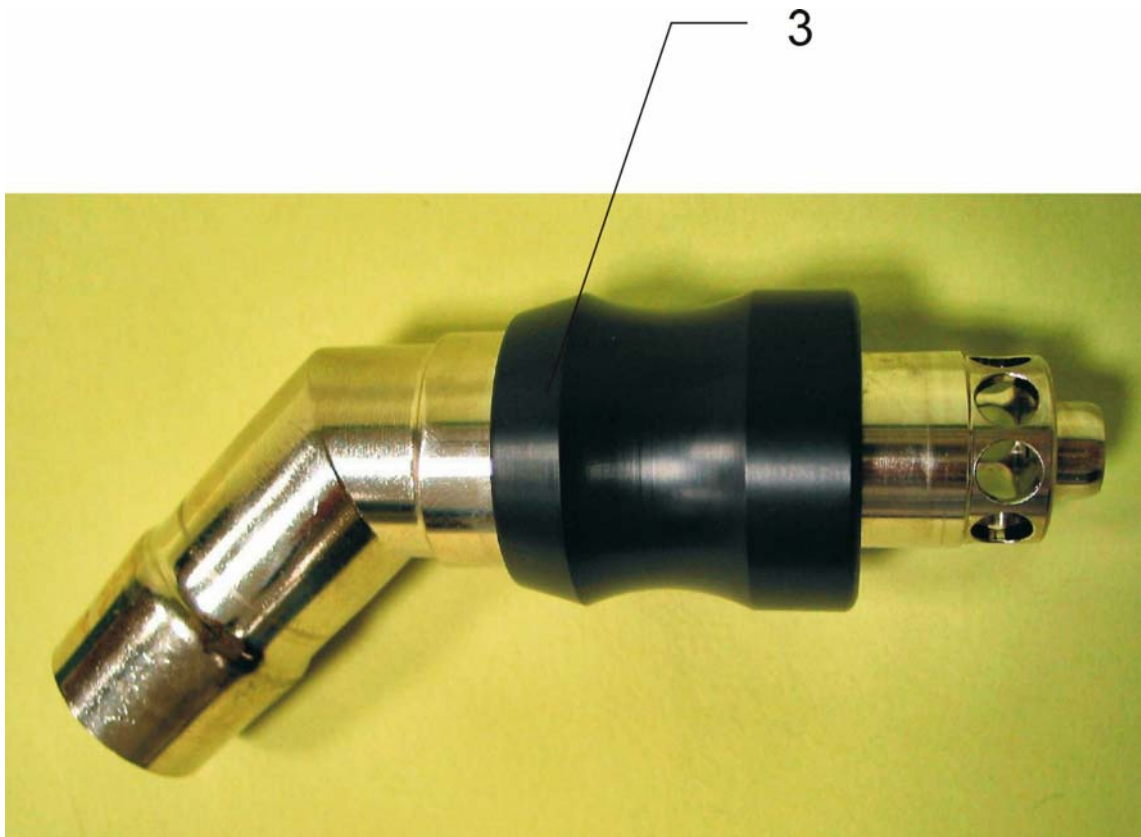

Item No.	Part No.	Description	Qty.	Qty. unit	Remark
3	G60440	ANAESTH.WASTE GAS PROBE 45	1.000	St	

Items that are shown in the illustration but are not listed below the illustration are not available as spare parts

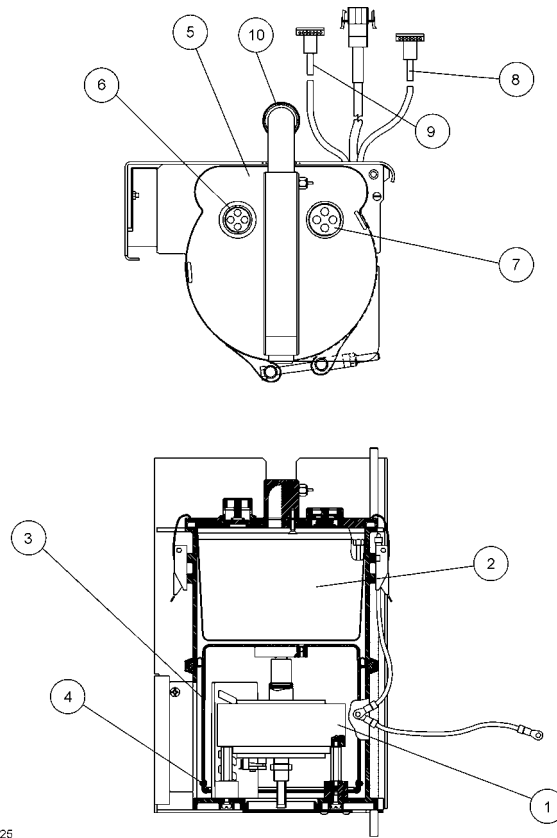

SV77025

Item No.	Part No.	Description	Qty.	Qty.u nit	Remark
2	2600650	DIAPHRAGM,CUP	1.000	St	
5	8604319	patient assembly	1.000	St	
10	2M08777	O-RING SEAL	1.000	St	

Items that are shown in the illustration but are not listed below the illustration are not available as spare parts

SV00419

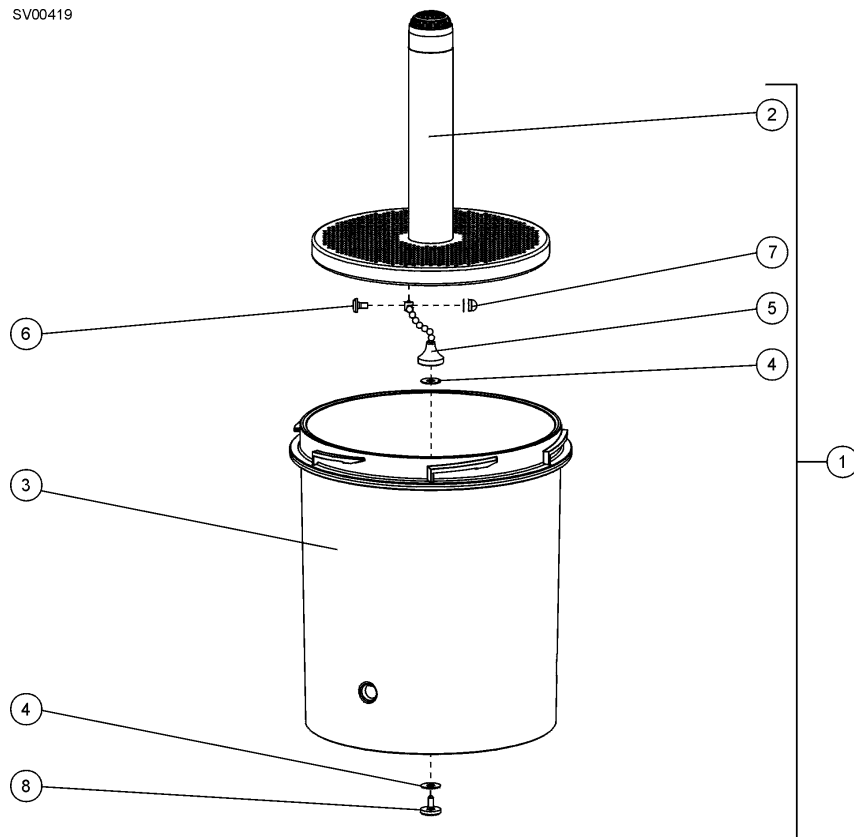

Item No.	Part No.	Description	Qty.	Qty.u nit	Remark
1	M29320	ABSORBER CICERO	1.000	St	
2	M29999	ABSORBER INSERT	1.000	St	
3	M29994	ABSORBER POT	1.000	St	

Items that are shown in the illustration but are not listed below the illustration are not available as spare parts

Assembly	Description	Part No.
<b>absorber</b>		
	ABSORBER CICERO	M29320
	ABSORBER INSERT	M29999
	ABSORBER POT	M29994
<b>AGGS-System</b>		
	AGS CONTAINER	M33292
	AGS-SYSTEM, BASIC UNIT	M33300
	FILTER	M33294
<b>AIR</b>		
	AIR CONNECTING HOSE 3M (BLACK)	M29241
	AIR CONNETING HOSE 1,5M(BLACK)	M29281
	AIR-CONNECTING HOSE 1,5M	M29279
	AIR-CONNECTING HOSE 5M	M29259
	AIR-CONNECTING HOSE 5M (BLACK)	M29261
	AIR-HOSE NIST 1,5M DIN PROBE	M34407
	AIR-HOSE NIST 3M DIN PROBE	M34408
	AIR-HOSE NIST 5M DIN PROBE	M34409
	AIR-ZV-HOSE 1,5M NIST EN-COLOR	8602519
	AIR-ZV-HOSE 3M NIST EN-COLOR	8602520
	AIR-ZV-HOSE 5M NIST EN-COLOR	8602521
<b>AIR/O2</b>		
	O2/AIR-CONNECTING HOSE 3M	M29243
	AIR/O2-ZV-HOSE 1,5M NIST EN-C.	8602525
	AIR/O2-ZV-HOSE 3M NIST EN-COL.	8602526
	AIR/O2-ZV-HOSE 5M NIST EN-COL.	8602527
	O2/AIR-HOSE NIST 1,5MDIN PROBE	M34410
	O2/AIR-HOSE NIST 3M DIN PROBE	M34411
	O2/AIR-HOSE NIST 5M DIN PROBE	M34412
	O2-AIR CONNECT.HOSE 3M(BLACK)	M29245
	O2-AIR CONNECT.HOSE 5M (BLACK)	M29265
	O2-AIR CONNECTING HOSE 1,5M	M29283
	O2-AIR CONNECTING HOSE 5M	M29263
	O2-AIR-CONNECT.HOSE 1,5(BLACK)	M29285
<b>Basic Unit</b>		
	AGS-SYSTEM, BASIC UNIT	M33300
<b>breathing system COSY2</b>		
	Membrane Asm	8604406



Assembly	Description	Part No.
<b>Central Air distributor</b>		
	AIR-DISTRIBUTOR 1,5M	M28963
	AIR-DISTRIBUTOR 1,5M (BLACK)	M29866
	AIR-DISTRIBUTOR 1,5M DIN PROBE	M34561
	AIR-DISTRIBUTOR 3M	M30709
	AIR-DISTRIBUTOR 3M (BLACK)	M30711
	AIR-DISTRIBUTOR 3M DIN-PROBE	M34562
	AIR-DISTRIBUTOR 5M	M30710
	AIR-DISTRIBUTOR 5M (BLACK)	M30712
	AIR-DISTRIBUTOR 5M DIN-PROBE	M34563
	AIR-ZV-DISTRIB.1,5M NIST EN-C.	8602531
	AIR-ZV-DISTRIB.3M NIST EN-COL.	8602532
	AIR-ZV-DISTRIB.5M NIST EN-COL.	8602533
<b>Central O2 distributor</b>		
	DIAPHRAGM SEPARATION	M34492
	O2-DISTR.1,5M DIN-ST.NIST-FN	M34941
	O2-HOSE NIST 5M DIN PROBE	M34403
	O2-ZV-DISTRIB.1,5M DIN BLUE	8602534
	O2-ZV-DISTRIB.1,5M DIN BLUE	8602534
	O2-ZV-DISTRIB.1,5M NIST EN-C.	8602528
	O2-ZV-DISTRIB.3M DIN BLUE	8602535
	O2-ZV-DISTRIB.3M DIN BLUE	8602535
	O2-ZV-DISTRIB.3M NIST EN-COLOR	8602529
	O2-ZV-DISTRIB.5M DIN BLUE	8602536
	O2-ZV-DISTRIB.5M DIN BLUE	8602536
	O2-ZV-DISTRIB.5M NIST EN-COLOR	8602530
<b>Clutch adapter</b>		
	Adapter AIR DIN/DIN-coupling	M28031
	Adapter AIR NIST/DIN-coupling	M35058
	ADAPTOR N2O NIST/DIN-COUPLING	M35057
	ADAPTOR O2 NIST/DIN-COUPLING	M35056
	N2O-COUPLING HOSE 0,15M	M23875
	O2-COUPLING HOSE 0,15M	M23874
<b>Hose DIN, device NIST</b>		
	ADAPTER O2 (DIN/NIST)	M32366
	ADAPTOR AIR (DIN/NIST)	M32368
	ADAPTOR AIR/O2 (DIN/NIST)	M32370
	ADAPTOR N2O (DIN/NIST)	M32367
	ADAPTOR VAC (DIN/NIST)	M32369

Assembly	Description	Part No.
<b>Hose DISS, device NIST</b>		
	ADAPTOR-AIR,DISS-NIST	M34877
	ADAPTOR-N2O,DISS-NIST	M34876
	ADAPTOR-O2,DISS-NIST	M34875
	ADAPTOR-VAC,DISS-NIST	M34878
<b>Hose NIST, device DIN</b>		
	ADAPTOR AIR (NIST/DIN)	M32495
	ADAPTOR AIR/O2 (NIST/DIN)	M32497
	ADAPTOR N2O (NIST/DIN)	M32494
	ADAPTOR O2 (NIST/DIN)	M32493
	ADAPTOR VAC (NIST/DIN)	M32496

<b>Assembly</b>	<b>Description</b>	<b>Part No.</b>
<b>Instructions for Use</b>		
	AGS A-Gas Awayline hu/cz	9038239
	AGS A-Gas Awayline ru/pl	9038207
	AGS A-Gas Awayline sv/no	9038206
	AGS A-Gas Awayline zh/jp	9038208
	GA Fabius GS 2.n en gb	9037933
	GA Fabius GS cs	9037794
	GA Fabius GS de	9037780
	GA Fabius GS en	9037781
	GA Fabius GS enUS	9037796
	GA Fabius GS es	9037784
	GA Fabius GS fr	9037782
	GA Fabius GS it	9037785
	GA Fabius GS ja	9037783
	GA Fabius GS nl	9037791
	GA Fabius GS no	9037786
	GA Fabius GS pl	9037792
	GA Fabius GS pt	9037788
	GA Fabius GS ro	9037795
	GA Fabius GS ru	9037787
	GA Fabius GS sv	9037793
	GA Fabius GS zh	9037789
	IfU Fabius GS 2.n cs	9037946
	IfU Fabius GS 2.n de	9037932
	IfU Fabius GS 2.n en us	9037948
	IfU Fabius GS 2.n es	9037936
	IfU Fabius GS 2.n fr	9037934
	IfU Fabius GS 2.n hu	9037942
	IfU Fabius GS 2.n it	9037937
	IfU Fabius GS 2.n ja	9037935
	IfU Fabius GS 2.n nl	9037943
	IfU Fabius GS 2.n no	9037938
	IfU Fabius GS 2.n pl	9037944
	IfU Fabius GS 2.n pt	9037940
	IfU Fabius GS 2.n ro	9037947
	IfU Fabius GS 2.n ru	9037939
	IfU Fabius GS 2.n sv	9037945
	IfU Fabius GS 2.n zh	9037941
	INSTRUCTIONS FOR USE AGS DA/IT	9029425
	Instructions for Use AGS de/en	9029327
	INSTRUCTIONS FOR USE AGS FR/ES	9029426
	INSTRUCTIONS FOR USE AGS FR/NL	9037424
<b>KIT AGS Adapter</b>		
	MODIF.AGS-ADAPTER TITUS/SA2	M32976

Assembly	Description	Part No.
<b>Maintanance Parts/Service Sets</b>		
	FILTER	M33294
<b>maintenance parts/Service kits</b>		
	CAPSULE FOR O2-DETECTOR (DW)	6850645
	HOSE 4X1,5-SI 50 SH A NF	1190520
	Hose Asm-PEEP/Pmax-APL Byp LFT	8604875
	Hose Asm-PEEP/Pmax-APL Byp RHS	8604874
	Set of 5 Spirolog sensors	8403735
	VALVE DISK	M23225
<b>Manuals Tiro</b>		
	IfU Fabius Tiro 2.n de	9038131
	IfU Fabius Tiro 2.n en	9038132
	IfU Fabius Tiro 2.n enUS	9038147
	IfU Fabius Tiro 2.n es	9038135
	IfU Fabius Tiro 2.n fr	9038133
	IfU Fabius Tiro 2.n it	9038136
	IfU Fabius Tiro 2.n nl	9038142
	TD Fabius Tiro de	9036220
	TD Fabius Tiro en	9036221
	TD Fabius Tiro es	9036222
	TD Fabius Tiro fr	9036223
<b>N2O</b>		
	N2O-CONNECT.HOSE 1,5M (BLACK)	M29277
	N2O-CONNECT.HOSE 3M (BLACK)	M29237
	N2O-CONNECT.HOSE 5M (BLACK)	M29257
	N2O-CONNECTING HOSE 1,5M	M29275
	N2O-CONNECTING HOSE 5M	M29255
	N2O-CONNECTION HOSE 3M	M29235
	N2O-HOSE NIST 1,5M DIN PROBE	M34404
	N2O-HOSE NIST 3M DIN PROBE	M34405
	N2O-HOSE NIST 5M DIN PROBE	M34406
	N2O-ZV-HOSE 1,5M NIST EN-COLOR	8602516
	N2O-ZV-HOSE 3M NIST EN-COLOR	8602517
	N2O-ZV-HOSE 5M NIST EN-COLOR	8602518

Assembly	Description	Part No.
<b>O2</b>		
	O2-CONNECT.HOSE 1,5M (BLACK)	M29273
	O2-CONNECT.HOSE 3M (BLACK)	M29233
	O2-CONNECT.HOSE 5M (BLACK)	M29253
	O2-CONNECTING HOSE 1,5M	M29271
	O2-CONNECTING HOSE 5M	M29251
	O2-CONNECTION HOSE 3M	M29231
	O2-HOSE NIST 1,5M DIN-PROBE	M34401
	O2-HOSE NIST 3M DIN PROBE	M34402
	O2-HOSE NIST 5M DIN PROBE	M34403
	O2-ZV-HOSE 1,5M NIST EN-COLOR	8602513
	O2-ZV-HOSE 5M NIST EN-COLOR	8602515
	O2-ZV-HOSE3M NIST EN-COLOR	8602514
<b>Plugs</b>		
	AGSS ANGLE PROBE / TYPE 1 / EN	G60495
	AGSS PROBE/STRAIGHT-TYPE1/ EN	G60580
	ANAESTH.WASTE GAS PROBE 45	G60440
<b>RS AGS- Schienenklaue</b>		
	Lever-type clamp	M25739
	MODIFICATION AGS-RAIL CLAMP	M32967
<b>Suction hoses</b>		
	AGS-SCAVANGER HOSE 0,5M	M35015
	AGS-SCAVANGER HOSE 1,5M	M33297
	AGS-SCAVANGER HOSE 3M	M33298
	AGS-SCAVANGER HOSE 5M	M33299
<b>VAC</b>		
	VAC.-CONNECT.HOSE 1,5M(BLACK)	M29289
	VAC.-CONNECT.HOSE 3M (BLACK)	M29249
	VAC.-CONNECT.HOSE 5M (BLACK)	M29269
	VAC-HOSE NIST 1,5M DIN PROBE	M34413
	VAC-HOSE NIST 3M DIN PROBE	M34414
	VAC-HOSE NIST 5M DIN PROBE	M34415
	VACUUM-CONNECTION HOSE 1,5M	M29287
	VACUUM-CONNECTION HOSE 3M	M29247
	VACUUM-CONNECTION HOSE 5M	M29267
	VAC-ZV-HOSE 1,5M NIST EN-COLOR	8602522
	VAC-ZV-HOSE 3M NIST EN-COLOR	8602523
	VAC-ZV-HOSE 5M NIST EN-COLOR	8602524
<b>Valve</b>		
	CAP 1,BLACK	M24597

Assembly	Description	Part No.
<b>ventilator</b>		
	DIAPHRAGM,CUP	2600650
	O-RING SEAL	2M08777
	patient assembly	8604319
<b>Without plug, color EN 739</b>		
	AIR-DISTRIBUTOR 5M,NO PLUG	M34564
	CS-HOSE N2O,5M,NO PLUG	M34417
	CS-HOSE AIR 5M, NO PROBE	M34418
	CS-HOSE AIR-O2,5M,NO PLUG	M34420
	CS-HOSE O2 5M, NO PROBE	M34416
	CS-HOSE VAC,5M,NO PLUG	M34419
	O2-DISTRIBUTOR 5M,NO PLUG	M34565
<b>Without plug, no color</b>		
	AIR-DISTRIB.NIST 5M,BL,N.PROBE	M32677
	AIR-HOSE 5M NIST BL., NO PROBE	M32039
	N2O-HOSE 5M,NIST,BL.,NO PROBE	M32038
	O2/AIR HOSE 5M NIST,BL.,NO PR.	M32047
	O2-DISTRIB.NIST 5M,BL,N.PROBE	M32679
	O2-HOSE 5M NIST BL., NO PROBE	M32037
	VAC.HOSE 5M,NIST,BL.,NO PROBE	M32046

2005-11-03

## Technical Documentation for Fabius GS / Fabius Tiro according to EMC standard IEC/EN 60601-1-2: 2001

### General Information

The EMC conformity includes the use of following external cables, transducers and accessories:

Designation	Order no.
Data cable 1 m Sub-D9 f/m 1:1	8601565
Data cable 2 m Sub-D9 f/m 1:1	8601474
Data cable 3 m Sub-D9 f/m 1:1	8601528

The Fabius GS / Fabius Tiro should not be used adjacent to or stacked with other equipment. If adjacent or stacked use is inevitable, the Fabius GS / Fabius Tiro should be observed to verify normal use in the configuration in which it will be used.

Other equipment which can be used adjacent to or stacked with the Fabius GS / Fabius Tiro are listed in the Instructions for Use manual, in the Accessories List / Family Drawing.

## Electromagnetic Emissions

<b>Electromagnetic Emissions</b>		
The Fabius GS / Fabius Tiro is intended for use in the electromagnetic environment specified below. The user should assure that is used in such an environment.		
<b>Emissions</b>	<b>Compliance according to</b>	<b>Electromagnetic environment</b>
RF emissions (CISPR 11)	Group 1	The Fabius GS / Fabius Tiro uses RF energy only for its internal function. Therefore, its RF emissions are very low and are not likely to cause any interference in nearby electronic equipment.
	Class B	The Fabius GS / Fabius Tiro is suitable for use in all establishments including domestic establishments and those directly connected to the public low-voltage power supply network that supplies buildings used for domestic purposes.
Harmonic emissions (IEC 61000-3-2)	Class A	N/A
Voltage fluctuations / flicker (IEC 61000-3-3)	Complies	N/A

Information re electromagnetic emissions (IEC 60101-1-2: 2001, table 201)



## Electromagnetic Immunity

Electromagnetic Immunity			
The Fabius GS / Fabius Tiro is intended for use in the electromagnetic environment specified below. The user should assure that is used in such an environment.			
Immunity against	IEC 60601-1-2 test level	Compliance level (of this equipment)	Electromagnetic environment
electrostatic discharge, ESD (IEC 61000-4-2)	contact discharge: $\pm 6$ kV air discharge: $\pm 8$ kV	$\pm 6$ kV $\pm 8$ kV	Floors should be wood, concrete or ceramic tile. If floors are covered with synthetic material, the relative humidity should be at least 30%.
electrical fast transients / bursts (IEC 61000-4-4)	power supply lines: $\pm 2$ kV longer input / output lines: $\pm 1$ kV	$\pm 2$ kV $\pm 1$ kV	Mains power quality should be that of a typical commercial or hospital environment.
surges on AC mains lines (IEC 61000-4-5)	common mode: $\pm 2$ kV differential mode: $\pm 1$ kV	$\pm 2$ kV $\pm 1$ kV	Mains power quality should be that of a typical commercial or hospital environment.
power frequency magnetic field 50/60 Hz (IEC 61000-4-8)	3 A/m	3 A/m	In close vicinity to the Fabius GS / Fabius Tiro, no equipment with extraordinary power frequency magnetic fields (power transformers, etc.) should be operated.
voltage dips and short interruptions on AC mains input lines (IEC 61000-4-11)	dip >95%, 0.5 periods dip 60%, 5 periods dip 30%, 25 periods dip >95%, 5 seconds	>95%, 0.5 per. 60%, 5 per. 30%, 25 per. >95%, 5 sec.	Mains power quality should be that of a typical commercial or hospital environment. If user requires continued operation during power mains interruptions, it is recommended to power the Fabius GS / Fabius Tiro from an uninterruptible supply or a battery.
radiated RF (IEC 61000-4-3)	80 MHz – 2.5 GHz: 10 (3) V/m	10 V/m	Recommended separation distance from portable and mobile RF transmitters with transmission power $P_{EIRP}$ to the Fabius GS / Fabius Tiro including its lines: $1.84 \text{ m} * \sqrt{P_{EIRP}}$ <sup>X1</sup>
RF coupled into lines (IEC 61000-4-6)	150 kHz – 80 MHz: 10 (3) V within ISM bands, 3 V outside ISM bands <sup>X2</sup>	10 V 3 V	Recommended separation distance from portable and mobile RF transmitters with transmission power $P_{EIRP}$ to the Fabius GS / Fabius Tiro including its lines: $1.84 \text{ m} * \sqrt{P_{EIRP}}$ <sup>X1</sup>

Information re electromagnetic immunity (IEC 60601-1-2: 2001, tables 202, 203, 204)

<sup>X1</sup>: For  $P_{EIRP}$  the highest possible "equivalent isotropic radiated power" of the adjacent RF transmitter has to be inserted (value in Watt). Also in the vicinity of equipment marked with the symbol



interference may occur. Field strengths from fixed, portable or mobile RF transmitters at the location of the Fabius GS / Fabius Tiro should be less than 3 V/m in the frequency range from 150 kHz to 2.5 GHz and less than 1 V/m above 2.5 GHz.

<sup>X2</sup>: ISM bands in this frequency range are: 6.765 MHz - 6.795 MHz, 13.553 MHz - 13.567 MHz, 26.957 MHz - 27.283 MHz, 40.66 MHz - 40.70 MHz.

## Recommended separation distances

<b>Recommended separation distances between portable and mobile RF telecommunication devices and the Fabius GS / Fabius Tiro</b>			
<b>max. P<sub>EIRP</sub> (W)</b>	<b>3 V/m distance* (m)</b>	<b>1 V/m distance* (m)</b>	<b>Note</b>
0.001	0.06	0.17	
0.003	0.10	0.30	
0.010	0.18	0.55	
0.030	0.32	0.95	e.g. WLAN 5250 / 5775 (Europe)
0.100	0.58	1.73	e.g. WLAN 2440 (Europe), Bluetooth
0.200	0.82	2.46	e.g. WLAN 5250 (not in Europe)
0.250	0.91	2.75	e.g. DECT devices
1.000	1.83	5.48	e.g. GSM 1800- / GSM 1900- / UMTS- mobiles, WLAN 5600 (not in Europe)
2.000	2.60	7.78	e.g. GSM 900 mobiles
3.000	3.16	9.49	

Information re separation distances (IEC 60601-1-2: 2001, tables 205 and 206)

\* 3 V/m distance to transmitters with frequencies from 150 kHz to 2.5 GHz, otherwise 1 V/m distance.



**Manufacturer:**

Dräger Medical AG & Co. KG  
Moislinger Allee 53 – 55  
D-23542 Lübeck  
Germany

Phone: (+49) (0) 1805-3723437

Fax: (+49) 451/882 - 3779



Subject to change without notice

Will not be replaced in the event of modifications.

© Copyright by Dräger Medical AG & Co. KG, Lübeck, Germany.

The warranty and liability conditions of the general terms and conditions for business transactions of Dräger Medical AG & Co. KG are not extended by this Technical Documentation.